

CITY OF  
**ANTIOCH**  
CALIFORNIA

**CALL OF SPECIAL MEETING**

Antioch City Council  
Special Meeting

Pursuant to Government Code section 54956, I hereby call a Special Meeting of the Antioch City Council. Said meeting shall be held on the following date, time and place:

**DATE:** Tuesday, December 15, 2020

**TIME:** 5:15 P.M. Special Meeting

**PLACE:** The City of Antioch, in response to the Executive Order of the Governor and the Order of the Health Officer of Contra Costa County concerning the Novel Coronavirus Disease, is making Antioch City Council meetings available via Comcast channel 24, AT&T U-verse channel 99, or live stream (at [www.antiochca.gov](http://www.antiochca.gov)).

The only items of business to be considered at such special meeting shall be set forth on the Special Meeting Agenda.

Dated: December 11, 2020



---

LAMAR THORPE, Mayor  
City of Antioch



## **ANNOTATED AGENDA**

### **Antioch City Council SPECIAL MEETING**

---

**Date: Tuesday, December 15, 2020**

**Time: 5:15 P.M. – Special Meeting**

**Place:** The City of Antioch, in response to the Executive Order of the Governor and the Order of the Health Officer of Contra Costa County concerning the Novel Coronavirus Disease, is making Antioch City Council meetings available via Comcast channel 24, AT&T U-verse channel 99, or live stream (at [www.antiochca.gov](http://www.antiochca.gov)).

If you wish to make a public comment, you may do so any of the following ways: **(1)** by filling out an online speaker card, located at [https://www.antiochca.gov/speaker\\_card](https://www.antiochca.gov/speaker_card), **(2)** by emailing the City Clerk prior to or during the meeting at [cityclerk@ci.antioch.ca.us](mailto:cityclerk@ci.antioch.ca.us), or **(3)** by dialing **(925) 776-3057** during the meeting.

The City cannot guarantee that its network and/or the site will be uninterrupted. To ensure that the City Council receives your comments, you are strongly encouraged to submit your comments in writing in advance of the meeting.

---

**Lamar Thorpe**, Mayor

**Monica E. Wilson**, Mayor Pro Tem (Council Member District 4)

**Tamisha Torres-Walker**, Council Member District 1

**Michael Barbanica**, Council Member District 2

**Lori Ogorchock**, Council Member District 3

**Ellie Householder**, City Clerk

**Lauren Posada**, City Treasurer

**Ron Bernal**, City Manager

**Thomas Lloyd Smith**, City Attorney

---

**Online Viewing:** <https://www.antiochca.gov/government/city-council-meetings/>

**Electronic Agenda Packet:** <https://www.antiochca.gov/government/agendas-and-minutes/city-council/>

**Project Plans:** <https://www.antiochca.gov/fc/community-development/planning/Project-Pipeline.pdf>

## SPEAKERS' RULES

**IMPORTANT NOTICE REGARDING THIS MEETING:** To protect our residents, officials, and staff, and aligned with the Governor's Executive Order N-29-20, certain teleconference requirements of the Brown Act have been suspended, including the requirement to provide a physical location for members of the public to participate in the meeting.

Members of the public seeking to observe the meeting may do so at [https://www.antiochca.gov/live\\_stream](https://www.antiochca.gov/live_stream), on Comcast Channel 24, or AT&T U-Verse Channel 99.

Members of the public wishing to provide public comment may do so in the following ways (#2 pertains to the Zoom Webinar):

1. Fill out an online speaker card located at: [https://www.antiochca.gov/speaker\\_card](https://www.antiochca.gov/speaker_card).
2. Provide oral public comments during the meeting by clicking the following link to register in advance to access the meeting via Zoom Webinar: <https://www.antiochca.gov/speakers>
  - You will be asked to enter an email address and a name. Your email address will not be disclosed to the public. After registering, you will receive an email with instructions on how to connect to the meeting.
  - When the Mayor announces public comments, click the "raise hand" feature in Zoom. For instructions on using the "raise hand" feature in Zoom, visit: [https://www.antiochca.gov/raise\\_hand](https://www.antiochca.gov/raise_hand).
3. Email comments to [cityclerk@ci.antioch.ca.us](mailto:cityclerk@ci.antioch.ca.us) **prior** to the Mayor announcing that public comment is closed, and the comment will be read into the record at the meeting (350 words maximum, up to 3 minutes, at the discretion of the Mayor). **IMPORTANT:** Identify the agenda item in the subject line of your email (i.e. "Public Comments" or a specific Agenda Item number). No one may speak more than once on an agenda item or during "Public Comments". All emails received will be entered into the record for the meeting.

Speakers will be notified shortly before they are called to speak.

- When called to speak, please limit your comments to the time allotted (350 words, up to 3 minutes, at the discretion of the Mayor).

After having heard from the public, the agenda item will be closed. Deliberations will then be limited to members of the City Council.

If the Council meeting appears to be going late, the City Council may decide to continue some items until a subsequent meeting. We will try to make this determination around 10:00 p.m. It is the goal of the City Council to stop discussing agenda items no later than 11:00 p.m.

In accordance with the Americans with Disabilities Act and California law, it is the policy of the City of Antioch to offer its public programs, services and meetings in a manner that is readily accessible to everyone, including individuals with disabilities. If you are a person with a disability and require information or materials in an appropriate alternative format; or if you require any other accommodation, please contact the ADA Coordinator at the number or address below at least 72 hours prior to the meeting or when you desire to receive services. Advance notification within this guideline will enable the City to make reasonable arrangements to ensure accessibility. The City's ADA Coordinator can be reached @ Phone: (925) 779-6950, and e-mail: [publicworks@ci.antioch.ca.us](mailto:publicworks@ci.antioch.ca.us).

### Notice of Availability of Reports

This agenda is a summary of the actions proposed to be taken by the City Council. For almost every agenda item, materials have been prepared by the City staff for the Council's consideration. These materials include staff reports which explain in detail the item before the Council and the reason for the recommendation. The materials may also include resolutions or ordinances which are proposed to be adopted. Other materials, such as maps and diagrams, may also be included. All of these materials are available online at: <https://www.antiochca.gov/government/agendas-and-minutes/city-council/>. Questions on these materials may be directed to the staff member who prepared them, or to the City Clerk's Office, who will refer you to the appropriate person.

### Notice of Opportunity to Address Council

The public has the opportunity to address the Council on each agenda item. To address the Council, fill out a Speaker Request form online at [https://www.antiochca.gov/speaker\\_card](https://www.antiochca.gov/speaker_card). See the Speakers' Rules on the inside cover of this Agenda. The Council can only take action on items that are listed on the agenda. Comments regarding matters not on this Agenda may be addressed during the "Public Comments" section.

**5:15 P.M.      ROLL CALL – CLOSED SESSION – for Council Members – *All Present***

**PUBLIC COMMENTS** for Closed Session – *None*

**CLOSED SESSION:**

**1) CONFERENCE WITH LEGAL COUNSEL – ANTICIPATED LITIGATION**

Initiation of Litigation pursuant to Government Code section 54956.9(c):  
Two cases.

*No reportable action*

**6:02 P.M.      ROLL CALL – SPECIAL MEETING – for Council Members – *All Present***

**PLEDGE OF ALLEGIANCE**

**PUBLIC COMMENTS** – *Members of the public may comment only on unagendized items. The public may comment on agendized items when they come up on this Agenda.*

**1.      CONSENT CALENDAR**

**A.      ACCEPTANCE OF WORK AND NOTICE OF COMPLETION FOR THE CITY HALL COUNCIL CHAMBERS REMODEL (GENERAL CONSTRUCTION) (P.W. 247-P)**

***Reso. No 2020/185 adopted, 5/0***

Recommended Action: It is recommended that the City Council adopt a resolution:

- 1) Authorizing a third amendment increasing the contract with Saboo, Inc. in the amount of \$147,983.84 for a total contract of \$1,862,008.15; and
- 2) Accepting work and authorizing the City Manager or designee to file a Notice of Completion for the Project.



## **COUNCIL REGULAR AGENDA**

### **2. CONSIDERATION OF BIDS FOR THE BRACKISH WATER DESALINATION PROJECT (P.W. 694)**

***Continued – TBD, 5/0***

Recommended Action: It is recommended that the City Council adopt a resolution:

- 1) Rejecting the bid protest of C. Overaa & Co. (“Overaa”);
- 2) Authorizing and directing the City Manager or designee to make the necessary Fiscal Year 2020/21 budget adjustments to increase the total budget for the Brackish Water Desalination Project (“Project”) to \$110,000,000;
- 3) Awarding the construction agreement (“Agreement”) for the Project to the lowest, responsive and responsible bidder Shimmick Construction Company, Inc.; and
- 4) Authorizing and directing the City Manager to execute the Agreement with Shimmick Construction Company, Inc. (“Shimmick”) for a total amount of \$86,689,000.

### **3. BRIDGING THE GAP VIRTUAL ROUNDTABLE DISCUSSIONS**

***Council support for process***

Recommended Action: It is recommended that the City Council provide staff direction.

### **4. RECONSIDERATION OF THE CITY’S ACCEPTANCE OF U.S. DEPARTMENT OF JUSTICE COPS HIRING PROGRAM GRANT FOR SCHOOL RESOURCE OFFICERS**

***Reso. No 2020/186 adopted, 3/2-No (Barbanica, Ogorchock)***

Recommended Action: It is recommended that the City Council consider whether to adopt the resolution rescinding Resolution No. 2020/121, which accepted grant funding in the amount of \$750,000 from the U.S. Department of Justice COPS Hiring Program to fund six (6) additional police officer positions to serve as School Resource Officers (SROs), and authorizing the City Manager or designee to amend the budget to reflect the cost savings as appropriate.

**7:50 P.M. ADJOURNED TO BREAK**

**8:03 P.M. RECONVENE. ROLL CALL for Council Members – All Present**

**COUNCIL REGULAR AGENDA – Continued**

**5. CITY COUNCIL APPOINTMENTS TO COUNCIL COMMITTEE ASSIGNMENTS AND AD HOC COMMITTEES**

Recommended Action: It is recommended that the City Council review and discuss City Council Committee Assignments and Ad Hoc Committees. Mayor Thorpe will be making new appointments for City Council approval by majority vote to be acted upon as follows:

- 1) Motion to approve all appointments for Mayor Thorpe,  
**Approved, 5/0**
- 2) Motion to approve all appointments for Mayor Pro Tem (Council Member District 4) – Wilson,  
**Approved, 4/0/1 (Wilson abstained)**
- 3) Motion to approve all appointments for Council Member District 1 – Torres-Walker,  
**Approved, 4/0/1 (Torres-Walker abstained)**
- 4) Motion to approve all appointments for Council Member District 2 – Barbanica; and  
**Approved, 4/0/1 (Barbanica abstained)**
- 5) Motion to approve all appointments for Council Member District 3 – Ogorchock.  
**[No appointments/assignments made]**

**PUBLIC COMMENT**

**STAFF COMMUNICATIONS**

**MOTION TO ADJOURN** – *The Mayor will make a motion to adjourn the meeting. A second of the motion is required, and then a majority vote is required to adjourn the meeting.*

***Motion to adjourn meeting at 10:08 p.m., 5/0***

CITY OF  
**ANTIOCH**  
CALIFORNIA

**STAFF REPORT TO THE CITY COUNCIL**

**DATE:** Special Meeting of December 15, 2020

**TO:** Honorable Mayor and Members of the City Council

**PREPARED BY:** Tracy Shearer, Assistant Engineer

**REVIEWED BY:** Scott Buenting, Project Manager *SB*

**APPROVED BY:** John Samuelson, Public Works Director/City Engineer *JS*

**SUBJECT:** Acceptance of Work and Notice of Completion for the City Hall Council Chambers Remodel (General Construction) P.W. 247-P

---

**RECOMMENDED ACTION**

It is recommended that the City Council adopt a resolution:

1. Authorizing a third amendment increasing the contract with Saboo, Inc. in the amount of \$147,983.84 for a total contract of \$1,862,008.15; and
2. Accepting work and authorizing the City Manager or designee to file a Notice of Completion for the Project.

**FISCAL IMPACT**

Adoption of this resolution will increase the existing contract with Saboo, Inc. by \$147,983.84 for a total contract of \$1,862,008.15 utilizing Public, Educational and Government ("PEG") Funds. These funds can only be used for equipment, capital improvement projects and maintenance of facilities that produce PEG video content.

**DISCUSSION**

On April 23, 2019, the City Council awarded a contract to Saboo for the City Hall Council Chambers Remodel (General Construction) project. This work included an interior remodeling of the existing City Hall Council Chambers, expansion of the Human Resources conference room and enclosure of the breezeway between the Council Chambers and City Hall.

On August 13, 2019, the City Council approved an amendment to the contract with Saboo to include furnishing and installing the new seating in the remodeled Council Chambers.

On November 26, 2019, the City Council approved a second amendment to the contract with Saboo to include improvements to the electrical, lighting and fire alarm systems,

increased sound proofing of the Human Resources conference room, upgrading of door hardware and modifications to the concrete flooring to bring the current building site into compliance with the Americans with Disabilities Act.

Staff is recommending an amendment to Saboo's contract to include performing additional work as part of the remodeling project. This work includes structural and architectural upgrades to the chambers and the adjacent breezeway, safety improvements to the dais, office renovations and installation of metal cladding on the breezeway awning to prevent further deterioration of the facility.

All work on this project was completed on December 2, 2020.

**ATTACHMENTS**

A: Resolution

B: Notice of Completion

ATTACHMENT "A"

RESOLUTION NO. 2020/\*\*

RESOLUTION OF THE CITY COUNCIL OF THE CITY OF ANTIOCH  
APPROVING THE THIRD AMENDMENT TO THE AGREEMENT WITH SABOO, INC.,  
AUTHORIZING ITS EXECUTION BY THE CITY MANAGER, AND AUTHORIZING  
THE CITY MANAGER OR DESIGNEE TO FILE A NOTICE OF COMPLETION FOR  
THE CITY HALL COUNCIL CHAMBERS REMODEL  
(GENERAL CONSTRUCTION)  
P.W. 247-P

**WHEREAS**, on June 12, 2018 the City Council adopted the 5 Year Capital Improvement Program 2018-2023, which included funding for City Hall Council Chambers Remodel (General Construction) project ("Project");

**WHEREAS**, the Project was published and advertised in the East County Times on February 22, 2019 and February 27, 2019 and a Notice to Contractors was sent to the construction trade journals;

**WHEREAS**, the Project bids were publicly opened and read on April 2, 2019, and two (2) bids were received;

**WHEREAS**, the lowest responsive and responsible bidder was submitted by Saboo, Inc. ("Saboo") of Brentwood;

**WHEREAS**, on April 23, 2019, the City Council approved an amendment increasing the 2018/2019 fiscal year Capital Improvement Budget with Public, Educational and Government Funds for the Project in the amount of \$300,000 and awarded a contract to Saboo in the amount of \$1,484,000 for the interior remodeling of the existing City Hall Council Chamber;

**WHEREAS**, on August 13, 2019, the City Council approved an amendment increasing the 2018-2019 fiscal year Capital Improvement Budget with Public, Educational and Government Funds for the Project in the amount of \$80,025;

**WHEREAS**, on November 26, 2019, the City Council approved an amendment increasing the 2019-2020 fiscal year Capital Improvement Budget with Public, Educational and Government Funds for the Project in the amount of \$150,000;

**WHEREAS**, the City Council has considered increasing the existing contract with Saboo in the amount of \$147,983.84 for a total contract of \$1,862,008.15;

**WHEREAS**, the City Council has considered accepting work and authorizing the City Manager or designee to file a Notice of Completion for the Project; and

**WHEREAS**, all work on the Project was completed on December 2, 2020 at a final contract price of \$1,862,008.15 in accordance with plans and specifications referred to therein.

AI



**RESOLUTION NO. 2020/\*\***

December 15, 2020

Page 2

**NOW, THEREFORE, BE IT RESOLVED** by the City Council of the City of Antioch, that:

1. The work on the Project is hereby completed and accepted.
2. The City Manager or designee is authorized to execute and file for record with the County Recorder, County of Contra Costa, a Notice of Completion thereof for the Project.
3. The City Council approves an increase to the existing contract with Saboo for this Project in the amount of \$147,983.84 for a total contract of \$1,862,008.15 and authorizes the City Manager, or designee, to take any actions and execute any documents or agreements necessary to carry out.

\* \* \* \* \*

**I HEREBY CERTIFY** that the foregoing resolution was passed and adopted by the City Council of the City of Antioch at a special meeting thereof held on the 15<sup>th</sup> day of December, 2020 by the following vote:

**AYES:**

**NOES:**

**ABSTAIN:**

**ABSENT:**

---

**ELIZABETH HOUSEHOLDER  
CITY CLERK OF THE CITY OF ANTIOCH**

A2



**ATTACHMENT "B"**

**RECORDED AT THE REQUEST  
OF:**  
CITY OF ANTIOCH, CA

**WHEN RECORDED MAIL TO:**  
CITY OF ANTIOCH  
CAPITAL IMPROVEMENTS DIVISION  
P.O. BOX 5007  
ANTIOCH, CA 94531  
(925) 779-7050

**THIS SPACE FOR RECORDER'S USE ONLY**

**NOTICE OF COMPLETION FOR THE  
CITY HALL COUNCIL CHAMBERS REMODEL  
(GENERAL CONSTRUCTION)  
IN THE CITY OF ANTIOCH  
(P.W. 247-P)**

**NOTICE IS HEREBY GIVEN:**

1. That the interest or estate stated in paragraph 3 herein the real property herein described is owned by: City of Antioch, 200 H Street, Antioch, California 94509.
2. That the full name and address of the Owner of said interest or estate, if there is only one Owner, and that the full names and addresses of all the co-owners who own said interest or estate as tenants in common, as joint tenants, or otherwise, if there is more than one owner, are set forth in the preceding paragraph.
3. That the nature of the stated owner, or if more than one owner, then of the stated owner and co-owners is: In fee.
4. That on December 2, 2020 the work and improvements hereinafter described, the contract for which was entered into by and between the City of Antioch and Saboo, Inc. was completed.
5. The surety for said project was American Contractors Indemnity Company.
6. This project consisted of remodeling the Council Chambers at City Hall, located at 200 H Street, Antioch, California.

**THE UNDERSIGNED STATES UNDER PENALTY OF  
PERJURY THAT THE ABOVE IS TRUE AND CORRECT**

\_\_\_\_\_  
Date

\_\_\_\_\_  
John Samuelson, P.E.  
Public Works Director/City Engineer  
City of Antioch

CITY OF  
**ANTIOCH**  
CALIFORNIA

**STAFF REPORT TO THE CITY COUNCIL**

**DATE:** Special Meeting of December 15, 2020

**TO:** Honorable Mayor and Members of the City Council

**SUBMITTED BY:** Scott Buenting, Project Manager

**APPROVED BY:** John Samuelson, Public Works Director/City Engineer <sup>JS</sup>

**SUBJECT:** Consideration of Bids for the Brackish Water Desalination Project  
(P.W. 694)

---

**RECOMMENDED ACTION**

It is recommended that the City Council adopt a resolution:

1. Rejecting the bid protest of C. Overaa & Co. ("Overaa");
2. Authorizing and directing the City Manager or designee to make the necessary fiscal year 20/21 budget adjustments to increase the total budget for the Brackish Water Desalination Project ("Project") to \$110,000,000;
3. Awarding the construction agreement ("Agreement") for the Project to the lowest, responsive and responsible bidder, Shimmick Construction Company, Inc.; and
4. Authorizing and directing the City Manager to execute the Agreement with Shimmick Construction Company, Inc. ("Shimmick") for a total amount of \$86,689,000.

**FISCAL IMPACT**

Adoption of this resolution will increase the Project budget to a total of \$110,000,000. Funding for this Project includes a California Department of Water Resources Desalination Grant (\$10,000,000), a State Water Resources Control Board Drinking Water Revolving Loan Fund award (\$56,000,000), California Department of Water Resources Settlement Agreement funds (\$27,000,000) and City of Antioch Water Enterprise Funds (\$17,000,000). The total budget includes the costs of planning, design, environmental documentation, permitting, construction including a 5% contract contingency, construction engineering and management, inspection, testing and contract administration of the project.

## **DISCUSSION**

On December 2, 2020, four (4) bids were received and opened, as shown on the attached tabulation. The low bid was submitted by Shimmick of Suisun City in the amount of \$86,689,000. The bids have been checked and found to be without errors or omissions.

On December 9, 2020, the second low bidder, Overaa protested the bid on the grounds that Shimmick was not responsive. Attachment D provides the bid protest, that in summary states that due to Schimmick's failure to provide marine prequalifications that include two past projects that meet the specifications, the bid should be considered non-responsive.

Section 00400, "Bid Form", Attachment L (of the bid forms), "Certification of Marine Subcontractor's Experience and Qualification", Article 1.02.B, "Marine Subcontractor Mandatory Minimum Experience Requirements" of the contract documents, in part, states the following:

"It is also acceptable for a Bidder to self-perform one of the work elements and subcontract the other work element specified in this section. For example, the two projects that meet the cofferdam requirements can be submitted by a qualified Bidder, while the dredging/disposal requirements can be submitted by a qualified Subcontractor. If the Bidder proposes this work arrangement, the Bidder must demonstrate that the above qualifications are met (two reference projects) for the portion of work they plan to self-perform. The Marine Subcontractor must also need to demonstrate qualifications for the portion of work they will perform (two reference projects). The Bidder must include an attachment to Certification Form L that explains the proposed separation of work responsibilities and provides references. Under the proposed arrangement, the bidder would be required to submit a total of four references (two for the Bidder and two for the Marine Subcontractor)."

December 11, 2020, Shimmick provided a response to Overaa's bid protest shown on Attachment E. Shimmick states they listed the wrong length of steel sheet piling on the Dumbarton Bridge Seismic Retrofit project in its Attachment L (of the bid forms). Specifically, Shimmick listed 25 feet in Attachment L and failed to capture the entirety of the work on the Dumbarton Bridge Seismic Retrofit project. Shimmick notes the Dumbarton Bridge Seismic Retrofit project included 60 feet of sheet piling, exceeding the requirement of 40 feet in Attachment L, and provides additional documentation to support this position. Additionally, the Bid Protest Response states a distinction between bid responsiveness and responsibility and Overaa's mischaracterization of Shimmick's lack of qualifications as an issue of bid responsiveness.

Staff has consulted with the City Attorney to determine Shimmick has submitted a responsive bid. Shimmick has proposed to self-perform the sheet pile work element and to subcontract out the dredging and disposal work element to Lind Marine, Inc. To demonstrate its experience in sheet pile work, Shimmick provides a list of four projects, Smith Canal Gate Project, Dumbarton Bridge Seismic Retrofit, Wallace Weir Fish Rescue Facility Construction, and Combined Pumping Plant and Fish Screen Project. Overaa's Bid Protest alleges these four projects are insufficient to demonstrate Shimmick is qualified to perform the work. Two of the four projects, Smith Canal Gate and Dumbarton



Bridge Seismic Retrofit, include the construction of at least 3,000 square feet of sheet piling, but only one of the four projects, Smith Canal Gate, includes sheet piling of at least 40 feet long.

As an initial matter, Overaa mischaracterizes Shimmick's lack of qualifications as an issue of bid responsiveness. A review of the Contract Documents clearly demonstrates Overaa misunderstands the purposes of Attachment L within the project bid forms. The title and content of Attachment L solely address the qualifications of each bidder (and if applicable, its subcontractor). In other words, and contrary to Overaa's mischaracterization of Attachment L as a matter of bid responsiveness, the clear purpose of the evaluation of a bidder's response to Attachment L is to evaluate bidder responsibility. That is, whether the bidder has demonstrated the attribute of trustworthiness, as well as quality, fitness, capacity, and experience to satisfactorily perform the Project. (See Pub. Contract Code, § 1103.) After a review of Shimmick's Attachment L, it appears Shimmick may not have the required experience; however, Shimmick's response to the Bid Protest indicates the Dumbarton Bridge Seismic Retrofit project in fact meets and exceeds the City's sheet piling requirement. Shimmick notes the project includes 60 feet of sheet piling and not the 25 feet stated in their Attachment L. Notwithstanding the Bid Protest Response, the Contract Specifications clearly give the City discretion to determine whether a particular bidder is sufficiently qualified to perform the work based on the qualifications presented by the bidder as part of their bid – Attachment L states "Notwithstanding anything contained in this Attachment L, it shall be in the City's sole discretion to determine whether the Marine Subcontractor is deemed qualified to perform the marine work on the Project." For clarification, "Marine Subcontractor" is synonymous with bidder when marine work is self-performed. Based on the foregoing, the City has the discretion to review Shimmick's responses in Attachment L and the Bid Protest Response in making a determination regarding whether Shimmick is a responsible bidder – i.e., whether Shimmick has demonstrated the attribute of trustworthiness, as well as quality, fitness, capacity, and experience to satisfactorily perform the Project. (See Pub. Contract Code, § 1103.)

Staff recommends rejecting Overaa's bid protest on account of (1) Overaa mischaracterization of Attachment L as a matter of bid responsiveness versus bidder responsibility and, (2) Shimmick demonstrating it in fact meets the experience requirements under Attachment L per its Bid Protest Response and awarding the contract to lowest, responsive and responsible bidder, Shimmick in the amount of \$86,689,000.

The Project is being implemented to improve the City's water supply reliability and provide operational flexibility while reducing costs, especially during droughts and with future proposed changes in Delta water management. The Project will allow the City to use water from its river intake year-round, even when the salinity is above levels normally treated at the existing conventional Water Treatment Plant.

This Project will generally consist of the construction of a brackish water desalination facility located within the fence line of the City's existing Water Treatment Plant ("WTP") with a capacity of 6 million gallons per day ("mgd"). The project also includes relocation and replacement of the City's existing San Joaquin River intake pump station with a new pump station including state of the art fish screens and construction of approximately 3,000 feet of new raw water pipeline connecting the new river pump pipeline to the City's

WTP. In addition, the Project includes the construction of a 4.3 mile long brine disposal pipeline from the new desalination facility to the existing Delta Diablo Wastewater Treatment Plant (Delta Diablo) outfall to convey approximately 2 mgd of brine for discharge from Delta Diablo's existing wastewater outfall.

**ATTACHMENTS**

- A: Resolution
- B: Bid Tabulation
- C: Construction Agreement
- D: Bid Protest from C. Overaa & Co.;
- E: Bid Protest Response Letter from Shimmick Construction Company, Inc.

ATTACHMENT "A"

RESOLUTION NO. 2020/\*\*

RESOLUTION OF THE CITY COUNCIL OF THE CITY OF ANTIOCH  
AMENDING THE FISCAL YEAR 20/21 CAPITAL IMPROVEMENT BUDGET,  
AWARDING THE BRACKISH WATER DESALINATION AGREEMENT, APPROVING  
A CONSTRUCTION AGREEMENT WITH SHIMMICK CONSTRUCTION COMPANY,  
INC., AND AUTHORIZING THE CITY MANAGER TO EXECUTE THE AGREEMENT  
P.W. 694

**WHEREAS**, City Council has considered directing the City Manager or designee to make the necessary budget adjustments to increase the total fiscal year 20/21 capital improvement budget for the Brackish Water Desalination Project ("Project") to \$110,000,000;

**WHEREAS**, the City Council has considered rejecting the bid protest of C. Overaa & Co.;

**WHEREAS**, the City Council has considered awarding the construction agreement ("Agreement") for the Project to the lowest, responsive and responsible bidder, Shimmick Construction Company, Inc. ("Shimmick"); and

**WHEREAS**, the City Council has considered authorizing the City Manager to execute the Agreement with Shimmick for a total amount of \$86,689,000.

**NOW, THEREFORE, BE IT RESOLVED** that the City Council of the City of Antioch hereby:

1. Authorizes and directs the City Manager or designee to make the necessary fiscal year 20/21 budget adjustments to increase the total capital improvement budget for the Brackish Water Desalination Project to \$110,000,000;
2. Rejects the bid protest of C. Overaa & Co.;
3. Awards the construction agreement for the Project to the lowest responsive and responsible bidder, Shimmick Construction Company, Inc.;
4. Approves an Agreement with Shimmick Construction Company, Inc., for a total amount of \$86,689,000 in substantially the form attached as "Attachment C to the staff report"; and
5. Authorizes and directs the City Manager to execute the Agreement in a form approved by the City Attorney.

\* \* \* \* \*

A1



**RESOLUTION NO. 2020/\*\***

December 15, 2020

Page 2

**I HEREBY CERTIFY** that the foregoing resolution was passed and adopted by the City Council of the City of Antioch at a special meeting thereof, held on the 15<sup>th</sup> day of December 2020, by the following vote:

**AYES:**

**NOES:**

**ABSTAIN:**

**ABSENT:**

---

**ELIZABETH HOUSEHOLDER  
CITY CLERK OF THE CITY OF ANTIOCH**

A2

**CITY OF ANTIOCH  
TABULATION OF BIDS**

**JOB TITLE:** Brackish Water Desalination  
(P.W. 694)

**BIDS OPENED:** December 2, 2020 ~ 2:00 p.m.  
Parking Lot Directly South of Antioch City Hall

	<b>Engineer's Estimate</b>	<b>Shimmick Construction Company, Inc. Suisun City</b>	<b>C. Overaa &amp; Co. Richmond</b>	<b>Kiewit Infrastructure West Co. Fairfield</b>	<b>Mountain Cascade, Inc. Livermore</b>
<b>TOTAL BID PRICE</b>	\$67,000,000.00	\$86,689,000.00	\$89,766,000.00	\$90,458,000.00	\$101,368,000.00

**LIST OF SUBCONTRACTORS**

<i>Shimmick Construction Company, Inc.</i>	<i>C. Overaa &amp; Co.</i>	<i>Kiewit Infrastructure West Co.</i>	<i>Mountain Cascade, Inc.</i>
<p><u>Structural Steel &amp; Metal Decking</u> Allied Steel Co., Inc. <u>Masonry</u> Utilion Inc. DBA PTS Masonry <u>Rebar</u> Gonsalves &amp; Santucci, Inc. DBA Conco <u>Horizontal Directional Drilling</u> The HDD Company, Inc. <u>Soil Nail, Rock Fall Drapery</u> Drill Tech Drilling &amp; Shoring, Inc. <u>Fencing</u> Crusader Fence Company, LLC <u>Electrical I&amp;C</u> Con J. Franke Electric, Inc. <u>Painting &amp; Coatings</u> Techno Coatings, Inc. <u>Underground Pipelines</u> A Teichert &amp; Son, Inc.</p>	<p><u>Demo</u> Silverado <u>Earthwork, Grading, Paving</u> Sarott <u>Pipeline</u> Mozingo <u>Marine Work</u> Power <u>Soil Nail/Shotcrete</u> Drill Tech <u>Rebar</u> Camblin <u>Masonry</u> Dorfmeier <u>Metals</u> GTE <u>Paintings/Coatings</u> FD Thomas <u>Plumbing/Pipe Installation</u></p>	<p><u>Soil Nail Walls Rock Netting</u> Drill Tech Drilling &amp; shoring, Inc. <u>Fences &amp; Gates</u> Crusader Fence Co., LLC <u>Metals</u> GTE Metals, Inc. <u>Rebar</u> Rebar International <u>Masonry</u> Dorfmeier Masonry Inc. <u>HVAC</u> Blocka Construction, Inc. <u>Horizontal Directional Drilling</u> Baileys Trenchless, Inc. <u>Offsite Pipeline</u> Teichert Construction <u>Electrical Labor Only</u> Mass Electric Construction Co. <u>Painting &amp; Coating</u></p>	<p><u>Marine</u> Dutra <u>Rebar</u> Conco <u>Masonry</u> Pen Gilly Masonry <u>Soil Nails &amp; Piers</u> Drill Tech <u>Concrete</u> R&amp;W Concrete <u>HDD</u> HDD Company <u>Painting</u> Redwood Painting <u>Electrical</u> Con J. Franke</p>

B  
1

Lescure  
HVAC  
Blocka  
Electrical  
Con J Franke  
System Integrator  
Tesco

FD Thomas, Inc.

B2

**ATTACHMENT "C"**

**AGREEMENT**

**AGREEMENT FOR THE CONSTRUCTION OF**

**CITY OF ANTIOCH BRACKISH WATER DESALINATION PROJECT**

**P.W. 694**

THIS AGREEMENT made and entered into this 15th day of December, 2020, between the CITY OF ANTIOCH, a municipal corporation of the State of California, hereinafter referred to as the "City" or "Owner" and , SHIMMICK CONSTRUCTION COMPANY, INC. , hereinafter referred to as the "Contractor";

**RECITALS**

WHEREAS, the City Council heretofore caused Drawings and Specifications for the Work hereinafter mentioned to be prepared, and therefore did approve and adopt the Drawings and Specifications; and

WHEREAS, the City Council did cause to be published for the time and in the manner required by law, a Notice inviting sealed Bids for the performance of the Work; and

WHEREAS, the Contractor, in response to such Notice, submitted to the City Council within the time specified in the Notice, and in the manner provided for therein, a sealed Bid for the performance of the Work specified in the Contract Documents, which the Bid, and the other Bids submitted in response to the Notice, the City publicly opened and canvassed in the manner provided by law; and

WHEREAS, the Contractor was the lowest responsible Bidder for the performance of the Work, and the City Council, as a result of the canvass of the Bids, did determine and declare Contractor to be the lowest responsible Bidder for the Work and award a Contract to Contractor to do the Work referred to in the aforementioned plans and specifications; and

WHEREAS, Contractor is ready, willing and able to complete all Work specified in the Contract Documents, in accordance with the Specifications, Drawings and all other terms and conditions of the Contract Documents; and

NOW, THEREFORE, in consideration of the mutual covenants hereinafter, the City and Contractor agree as follows:

**ARTICLE 1 – SCOPE OF WORK**

**1.1 The Work.** The Contractor shall furnish all labor, materials, tools, apparatus, equipment, transportation, insurance, bonds, special services and skill to construct and complete in good workmanlike and substantial manner to the satisfaction of the City all the Work called for, and in the manner designated in, and in strict conformity with the Contract Documents for the project entitled: **City of Antioch Brackish Water Desalination Project**. All incidental work not shown on the Plans or specified herein which is necessary to complete the Work so as to provide the project described, or shown, shall be furnished and installed as part of this Contract at no additional cost to the City.

CI



1.2 **Location of Work.** The Work will be performed at the following location: City of Antioch and Contra Costa County as shown on the Contract Drawings.

## ARTICLE 2 – CONTRACT DOCUMENTS

### 2.1 **Contract Documents.**

The Contract Documents consist of the following documents:

- Bidding Requirements (Sections 00100 through 00400. Does not include Section 00300, Supplemental Project Information Available to Bidders);
- Contracting Requirements (Sections 00510 through 00800);
- General Requirements (Division 1);
- Technical Specifications (Division 2 and all other Divisions following);
- City Standard Specifications
- Contract Drawings;
- Addenda (numbers 1 to 8, inclusive);
- Permits from other agencies as may be required by law; and
- All other documents incorporated by reference into these Contract Documents.
- The following which may be delivered or issued on or after the Effective Date of the Agreement and are not attached hereto:
  - Notice to Proceed (Section 00600);
  - Field Directive(s);
  - Change Order(s);
  - Construction Change Directive; and
  - Field Order(s).

2.2 **Not Contract Documents.** There are no Contract Documents other than those listed in this Section 00510, Article 2, Contract Documents, Section 00300, Supplemental Project Information Available to Bidders, and the information supplied therein, are not Contract Documents. The Contract Documents may only be amended, modified or supplemented as provided for in Section 00700, General Conditions and Section 00800, Supplemental General Conditions.

2.3 **Definitions and Terms.** Unless otherwise specifically provided herein, all terms, words and phrases defined in Section 00700- 1.02, Definitions of Words and Terms, shall have the same meaning and intent in this Agreement.

2.4 **Entire Contract; Interpretation.** This Agreement, together with the Contract Documents, constitutes the entire agreement between the Parties with respect to the subject matter hereof, and supersedes all prior oral or written agreements between the Parties with respect thereto (including without limitation, City's award of the Contract to Contractor and any applicable letter of intent), unless such agreement is expressly incorporated herein. City makes no representations or warranties, express or implied, not specified in this Agreement or the Contract Documents. This Agreement and the Contract Documents are the product of negotiation between the Parties. Accordingly, any rule of construction of contracts (including, without limitation, California Civil Code §1654) that ambiguities are to be construed against the drafting party shall not be employed in the interpretation of this Agreement or the Contract Documents.

2.5 **Severability.** Any provision or part of the Contract Documents held to be void or unenforceable under any Law or Regulation shall be deemed stricken, and all remaining provisions shall continue to be valid and binding upon City and Contractor, who agree that the Contract Documents shall be reformed to replace such stricken provision or part thereof with a valid and enforceable provision that comes as close as possible to expressing the intention of the stricken provision.

2.6 **Amendments.** The terms of this Agreement or the Contract Documents shall not be waived, altered, modified, supplemented or amended in any manner whatsoever except as authorized by the Contract documents or by a written instrument signed by the Parties.

**2.7 Further Assurances.** The Parties shall cooperate fully in the execution of any and all other documents and in the completion of any additional actions that may be necessary or appropriate to give full force and effect to the terms and intent of this Agreement and the Contract Documents.

**ARTICLE 3 – CONTRACT PRICE**

**3.1 Contract Price Breakdown.** Subject to additions and deductions by Change Order(s) as provided in the Contract Documents, the City agrees to pay and Contractor agrees to accept, in full payment for completion of the Work in accordance with the Contract Documents as follows:

**BID SCHEDULE**

Bid Items				
Item	Description	Approx. quantity	Unit	Total bid item price, dollars
1.	Mobilization/Demobilization (not to exceed 6% of Total Bid Price)	1 Job	L.S.	\$5,000,000.00
2.	Sheeting, shoring, and bracing, or equivalent method for the protection of life and limb in trenches and open excavations, pursuant to California Labor Code Sections 6705 and 6707.	1 Job	L.S.	\$350,000.00
3	Water Treatment Plant Work	1 Job	L.S.	\$60,179,000.00
4.	Wonderware SCADA operating system	1 Job	L.S.	\$150,000.00
5.	River Pump Station Non-Marine Work	1 Job	L.S.	\$10,000,000.00
6.	River Pump Station Marine Work	1 Job	L.S.	\$4,000,000.00
7.	Work at Delta Diablo WWTP	1 Job	L.S.	\$300,000.00
8.	Brine Disposal Pipeline Work Outside of Water Treatment Plant	1 Job	L.S.	\$3,000,000.00
9.	Raw Water Pipeline Work Outside of Water Treatment Plant	1 Job	L.S.	\$2,000,000.00
10.	Allowance for Additional Concrete Basin Repairs	1 Job	All	\$50,000.00
11.	Allowance for Unforeseen Underground Utility Conflicts	1 Job	All	\$500,000.00
12.	Subsurface Utility Engineering	1 Job	L.S.	\$50,000.00
13.	Disposal of Contaminated Soil at River Pump Station Site	1 Job	L.S.	\$10,000.00
14.	Disposal of Contaminated Groundwater at River Pump Station Site	1 Job	L.S.	\$200,000.00
15.	Chemical Flow Meters	1 Job	L.S.	\$90,000
16.	Video Inspection and Injection of CLSM in Void Under Slab Near Plant A Filters	20	CYD	\$10,000.00
17.	All Work in accordance with the Contract Documents, with the exception of work included under bid Items 1 through 16.	1 Job	L.S.	\$800,000.00

TOTAL BID AWARD PRICE (Items 1 through 17) **\$86,689,000.00**

*CB*



TOTAL BID AWARD PRICE (in words) Eighty-six million, six hundred eighty-nine thousand dollars.

The above Total Contract Price includes all allowances, if any, provided for in the Contract Documents. Progress and final payments shall be in accordance with the General Conditions.

When, under the provisions of this Agreement, the City shall charge any sum of money against Contractor, City shall deduct and retain the amount of such charge from the amount of the next succeeding progress estimate, or from any other moneys due or that may become due to the Contractor from City. If, on completion or termination of the Contract, sums due Contractor are insufficient to pay City's charges against him, the City shall have the right to recover the balance from Contractor or its sureties.

Compensation for Unit Price Items shall be based upon the unit prices stated in above schedule times the actual quantities or units of work and materials performed or furnished. Unit prices paid by the City may change depending on actual quantities or units or work completed in accordance with Section 00700-9.04, Increased or Decreased Quantities.

**3.2 Substitution of Securities for Money Withheld.** At any time prior to final payment, Contractor may request substitution of securities for any money withheld by the City to ensure performance of the Agreement in the manner as provided by California Public Contract Code §22300. At the expense of the Contractor, securities equivalent to the money withheld may be deposited with the City or with an approved financial institution as escrow agent according to a separate Security Agreement. Securities eligible for substitution shall include those listed in §16430 of the California Government Code or bank or savings and loan certificates of deposit.

#### ARTICLE 4 – CONTRACT TIMES

**4.1 Time is of the Essence.** All time limits for Milestones, if any, Substantial Completion, and completion and readiness for final payment as stated in the Contract Documents are of the essence of this Agreement.

**4.2 Commence Work.** Contractor shall commence execution of the Work on the date established in the Notice to Proceed. The City reserves the right to modify or alter the Commencement Date of the Work.

**4.3 Days to Achieve Contract Times.** The Contractor shall diligently execute the Work to complete each Milestone listed below within the following number of consecutive calendar days from the date established in the Notice to Proceed for the commencement of the Contract Time.

**Times Allowed for Completion**

Contractual Completion Event	Completion Time (# of calendar days from Notice to Proceed date) or Seasonal Dates
Milestone #1	April 30, 2021
Milestone #2	October 31, 2021
Milestone #3	March 31, 2022
Milestone #4	April 30, 2022
Milestone #5	July 31, 2022
Substantial Completion	810
Final Completion	850

c4

**Milestones** – Milestones are further defined in Section 01140, Work Restrictions and Section 00800, Supplementary Conditions.

**4.4 Liquidated Damages.** The City and Contractor recognize that time is of the essence of this Agreement and that the City will suffer financial loss if the Work is not completed within the contract times specified in 4.3, **Days to Achieve Contract Times**. The actual fact of the occurrences of damages and the actual amount of the damages which City would suffer if the Work were not completed within the specified times set forth above are dependent upon many circumstances and conditions which could prevail in various combinations, and, from the nature of the case, it would be impracticable and extremely difficult to fix the actual damages.

Damages which City would suffer in the event of delay include loss of the use of the Project, and, in addition, expenses of prolonged employment of an architectural and engineering staff; costs of administration, construction management, inspection, and supervision; the loss suffered by the public within the City's constituent cities by reasons of the delay in the completion of the project to serve the public at the earliest possible time; and, costs associated with ongoing and extended permit compliance.

Accordingly, the City and the Contractor agree that as liquidated damages for delay, in accordance with California Government Code Section 53069.85, the Contractor will forfeit and pay to the City liquidated damages in the amounts set forth in the table below, per day for each and every calendar day that expires after the time for completion specified in the above section 4.3, Days to Achieve Contract Times, except as otherwise provided by extension of time pursuant to Section 00700-8.04, Time Extensions, of the General Conditions.

It is further understood and agreed in accordance with California Government Code Section 53069.85 that the liquidated damages sum specified in this provision is not manifestly unreasonable under the circumstances existing at the time this Contract was made, and that the City may deduct liquidated damages sums in accordance with this provision from any payments due or that may become due the Contractor.

**Damages for Delays**

Milestone	Contractual Completion Event	Dollars Per Day Liquidated Damages (Amount in Dollars)
1	Project Completion Deadline 1 (Milestone 1)	\$10,000
2	Project Completion Deadline 2 (Milestone 2)	\$10,000
3	Project Completion Deadline 3 (Milestone 3)	\$10,000
4	Project Completion Deadline 4 (Milestone 4)	\$10,000
5	Project Completion Deadline 5 (Milestone 5)	\$10,000
	Substantial Completion	\$1,600
	Final Completion	\$800

**4.6 Damages for Violations of Environmental Impact Mitigation Requirements.** The Contractor recognizes that the City has defined environmental controls for the Work to promote compliance with the environmental impact mitigation requirements identified in the City's certified Final Initial Study / Mitigated Negative Declaration and related mitigation monitoring and reporting plan for the Work. In addition to the liquidated damages specified in Section 4.4, **Liquidated Damages**, the City and the Contractor agree that penalties imposed on and costs incurred by the City as a result of violations of such requirements caused by the actions or inactions of the Contractor, its employees, or subcontractors, the Contractor will forfeit and pay the City any and all penalties and costs for such violations, up to a maximum of \$10,000



per calendar day. Costs related to such penalties and violations include, without limitation, City staff time, City equipment costs, materials, City's consultants and legal fees.

## ARTICLE 5 – INSURANCE AND BONDS

**5.1 Insurance.** Contractor shall maintain in full force and effect at all times during the term of the Agreement, at its sole expense, policies of insurance in accordance with the General Conditions and the Supplementary Special Conditions. By execution of this Agreement, the Contractor certifies as follows:

"I am aware of the provisions of §3700 of the Labor Code which require every employer to be insured against liability for workers' compensation or to undertake self-insurance in accordance with the provisions of that code, and I will comply with such provisions before commencing the performance of the Work of this contract."

**5.2 Faithful Performance Bond and Payment Bond.** The Contractor, simultaneously with the execution of the Agreement, will be required to furnish a Faithful Performance Bond to guarantee the Faithful Performance of the Contract equal to one hundred (100%) of the Total Contract Price set forth in Article 4 and a Payment Bond required by Part 4, Title 15, Chapter 7, Division Three of the Civil Code of the State of California equal to one hundred percent (100%) of the Total Contract Price set forth in Article 4. The bonds must be issued by a surety company admitted in California and with a current A.M. Best's rating of no less than A-:VII or equivalent, unless otherwise approved by Agency.

Any alteration(s) made in any provision of this Agreement shall not operate to release any surety from liability on any bond required hereunder and the consent to make such alteration(s) is hereby given, and any surety on said bonds hereby waives the provisions of Sections 2819 and 2845 of the California Civil Code.

Contractor must submit the following document with the bonds: The original, or a certified copy, of the unrevoked appointment, power of attorney, bylaws or other instrument entitling or authorizing the person who executed the bond to do so.

## ARTICLE 6 – CITY'S REPRESENTATIVE(S) AND AUTHORITY'S CONSULTANTS

**6.1 City's Representative.** The City has designated **Scott Buenting**, or his/her designee to act as City's Representative. The City may change the individual(s) acting as City's Representative(s), or delegate one or more specific functions to one or more specific City's Representative at any time with notice and without liability to Contractor. Each City's Representative is the beneficiary of all Contractor obligations to the City, including without limitation, all releases and indemnities. All documents requiring the signature/approval of City shall be signed by the City's Representative.

**6.2 Design Engineer.** The City has designated **Carollo Engineers** to act as Design Engineer. The Design Engineer is included within and covered by Contractor's release and indemnity obligations to the City.

**6.3 Construction Manager.** The City has designated **CDM-Smith, Inc.** to act as Construction Manager. The City may assign, upon mutual agreement, all or part of the City's Representative's duties, rights and responsibilities to the Construction Manager. The Construction Manager is the beneficiary of all Contractor obligations to the City, including without limitation, all releases and indemnities.

## ARTICLE 7 – CONTRACTOR'S REPRESENTATIONS

**7.1 Representations and Warranties.** In order to induce the City to enter into this Agreement, Contractor makes the following representations and warranties:

- A. Contractor has visited the Site and has examined thoroughly and understood the nature and extent of the Contract Documents, Work, Site, locality, actual conditions, and all local conditions, and federal, state and local laws and regulations that in any manner may affect cost, progress, performance or furnishing of Work or which relate to any aspect of the means, methods,

techniques, sequences or procedures of construction to be employed by Contractor and safety precautions and programs incident thereto.

- B. Contractor has examined thoroughly and understood all reports of exploration and tests of subsurface conditions, record drawings, drawings, products specifications or reports, available for bidding purposes, of physical conditions, including Underground Facilities, which are identified in Section 00300, Supplemental Project Information Available to Bidders, or which may appear in the Contract Documents. Contractor further acknowledges and agrees that, in executing the Agreement, it is relying on its own observation of (1) the site of the Work, (2) access to the Site, (3) all other data and matters requisite to the fulfillment of the Work and on its own knowledge of existing facilities on and in the vicinity of the site of the Work to be constructed under the Contract, (4) the conditions to be encountered, (5) the character, quality and scope of the proposed Work, (6) the quality and quantity of the materials to be furnished, and (7) the requirements of the Contract, the plans, the specifications, and other related information made available to Contractor by the City.
- C. Contractor has correlated its knowledge and the results of all such observations, examinations, investigations, explorations, tests, reports and studies with the terms and conditions of the Contract Documents.
- D. Contractor has given the City prompt written notice of all conflicts, errors, ambiguities, or discrepancies that it has discovered in or among the Contract Documents and record drawings and actual conditions and the written resolution thereof (if any) through Addenda issued by the City is acceptable to Contractor.
- E. Contractor is duly organized, existing and in good standing under applicable state law, and is duly qualified to conduct business in the State of California.
- F. Contractor has duly authorized the execution, delivery and performance of this Agreement, the other Contract Documents and the Work to be performed herein. The Contract Documents do not violate or create a default under any instrument, agreement, order or decree binding on Contractor.



Contractor has listed the following Subcontractors consistent with the Subcontractor Listing Law, California Public Contract Code §4100 <i>et seq.</i> : <b>Name of Subcontractor and Address of Mill or Shop</b>	<b>Description of Subcontractor's Work</b>	<b>Subcontractor's License No.</b>
Allied Steel Co., Inc. 1027 Palmyrita Ave. Riverside, CA 92057	Structural Steel & metal Decking	164718
Utilion Inc. DBA P.T.S. Masonry 7117 Tokay Ave. Sacramento, CA 95827	Masonry	704533
Gonsalves & Santucci, Inc. 5141 Commercial Circle Concord, CA 94520	Rebar	199902
The HDD Company, Inc. 4525 Serrano Parkway, Suite 210 El Dorado Hills, CA 95762	Horizontal Directional Drilling	858987
Drill Tech Drilling & Shoring, Inc. 2200 Wymore Way Antioch, CA 94509	Soil Nail, Rock Fall Drapery	745354
A. Teichert & Son, Inc. 3500 American River Drive Sacramento, CA 95864	Underground Pipelines	8
Crusader Fence Company, LLC 3115 Gold Valley Drive Rancho Cordova, CA 95742	Fencing	1056652
Con J. Franke Electric, Inc. 317 N. Grant Street Stockton, CA 95202	Electrical I&C	288366
Techno Coatings, Inc. 1391 S. Allec Street Anaheim, CA 92805	Painting & Coatings	296517

**ARTICLE 8 – LABOR CODE COMPLIANCE AND DAVIS-BACON WAGES**

**8.1 California Labor Code.** Pursuant to the provisions of §1770 *et seq.* of the California Labor Code, which are hereby incorporated by reference and made a part hereof, the Director of the Department of Industrial Relations has determined the general prevailing rate of the per diem wages and the general prevailing rate for holiday and overtime Work in the locality in which the Work is to be performed, for each craft, classification or type of worker needed to perform the Work. Per diem wages shall be deemed to include employer payments for health and welfare, pension, vacation, apprenticeship or other training programs, and similar purposes. Copies of the rates are on file at City Public Works Department office, or may be downloaded from the State Department of Industrial Relations website, Division of Labor Statistics and Research, <http://www.dir.ca.gov/dlsr/>. The rate of prevailing wage for any craft, classification or type of workmanship to be employed in performing the Work is the rate established by the applicable collective bargaining contract which rate so provided is hereby adopted by reference and shall be effective for the life of this Agreement or until the Director of the Department of Industrial Relations determines that another rate is adopted.

It shall be mandatory for the Contractor and all subcontractors to pay not less than such specified prevailing wage rates to all workers employed in the performance of the Work. If any worker engaged in the performance of the Work is paid less than the specified prevailing wage rate, the Contractor shall pay to each such worker the difference between the specified prevailing wage rate and the actual amount paid to such worker for each calendar day or portion thereof. In addition, Contractor shall comply with the provisions

of California Labor Code §1775, including provisions which require Contractor to (a) forfeit as penalty to City not more than \$200 for each calendar day or portion thereof for each worker (whether employed by Contractor or any Subcontractor) paid less than the applicable prevailing wage rates for any work done under this Contract in violation of the provisions of the California Labor Code, and (b) pay to each worker the difference between the prevailing wage rate and the amount paid to each worker for each calendar day or portion thereof for which the worker was paid less than the prevailing wage.

The Contractor and each Subcontractor shall keep or cause to be kept an accurate record showing the names, addresses, social security numbers, work classifications, straight time and overtime hours worked each day and week for all laborers, workers and mechanics employed in connection with the performance under the Contract Documents or any subcontract thereunder, and showing the actual per diem wage paid to each of such workers, which records shall be open at all reasonable hours to inspection by City and its agents and to the representatives of the Division of Labor Law Enforcement of the State Department of Industrial Relations. Contractor assumes all responsibility for such payments and shall defend, indemnify and hold the City harmless from any and all claims made by the State of California, the Department of Industrial Relations, any Subcontractor, any worker or any other third party with regard thereto. Contractor shall be responsible to ensure compliance with section 1776. Failure to comply with that section may result in the California Labor Commissioner's assessment of a penalty of \$100 per day per affected worker.

The Contractor shall post, at each jobsite, a copy of such prevailing rate of per diem wages as determined by the Director for the California Department of Industrial Relations.

The successful Bidder and its subcontractors shall employ the appropriate number of apprentices, in each apprenticeable craft, on the project site as stipulated in California Labor Code sections 1777.5, 1777.6 and 1777.7. Failure to comply may result in the California Labor Commissioner's assessment of a penalty of \$100 for each day of noncompliance.

Pursuant to California Labor Code Section 1771.1, by execution below, the Bidder and its Subcontractors certify that when the Bidder's bid was submitted, the Bidder and its Subcontractors were registered and qualified to perform public work pursuant to Section 1725.5 of the California Labor Code, subject to limited legal exceptions. Pursuant to California Labor Code Section 1771.1, by execution below, the Bidder and its Subcontractors certify that they are registered and qualified to perform public work pursuant to Section 1725.5 of the California Labor Code, subject to limited legal exceptions.

**8.2 Davis-Bacon Wages.** Pursuant to State Water Resources Control Board (SWRCB) Division of Financial Assistance Guidelines for Clean Water State Revolving Fund (CWSRF), the successful bidder must comply with the Davis-Bacon Act (40 U.S.C. 276a to a-7) as supplemental by Department of Labor regulations (29 CFR Part 5) it shall be mandatory upon the Contractor to whom the work is awarded and upon any Subcontractor under the Contractor to pay not less than Davis-Bacon wage rates. A copy of said wage rates is on file at City Public Works Department office and in Specification Section 00225, Davis Bacon Wage Determinations. These rate determinations may also be found on the Department of Labor's website at: <http://www.dol.gov/dba.aspx>. It shall be mandatory upon the Contractor to whom the work is awarded and upon any Subcontractor under the Contractor to pay not less than State prevailing wage rates or Davis-Bacon wage rates, whichever is higher, to all workmen employed by them in the execution of the Contract.

## **ARTICLE 9 – MISCELLANEOUS PROVISIONS**

**9.1 Assignment.** Contractor shall not assign this Contract or any rights under or interests in the Contract without the City's written approval. No assignment will release or discharge the Contractor from any duty or responsibility under the Contract Documents.

**9.2 Successors and Assigns; No Third Party Beneficiaries.** The provisions of this Agreement and the Contract Documents shall inure to the benefit of and shall apply to and bind the successors and permitted assigns of the Parties. Nothing contained in this Agreement or the Contract Documents is



intended to or shall be deemed to confer upon any person, other than the Parties and their respective successors and permitted assigns, any rights or remedies hereunder.

**9.3 Contractor Bankrupt.** If Contractor should commence any proceeding under federal bankruptcy law, or if Contractor be adjudged a bankrupt, or if Contractor should make any assignment for the benefit of creditors, or if a receiver should be appointed on account of Contractor's insolvency, then the City may, without prejudice to any other right or remedy, terminate the Agreement and complete the Work by giving notice to Contractor and its surety according to the General Conditions.

The City shall have the right to complete, or cause completion of the Work, all as specified in the General Conditions.

**9.4 Unfair Competition.** The following provision is included in this Agreement pursuant to California Public Contract Code §7103.5.

"In entering into a public works contract or a subcontract to supply goods, services, or materials pursuant to a public works contract, the contractor or subcontractor offers and agrees to assigning to the awarding body all rights, title, and interest in and to all causes of action it may have under Section 4 of the Clayton Act (15 U.S.C. Sec. 15) or under the Cartwright Act (Chapter 2 (commencing with §16700) of Part 2 of Division 7 of the Business and Professions Code), arising from purchases of goods, services, or materials pursuant to the public works contract or the subcontract. This assignment shall be made and become effective at the time the awarding body tenders final payment to the contractor, with further acknowledgment by the parties."

**9.5 Nondiscrimination and Equal Opportunity.** The Contractor shall not discriminate on the basis of a person's race, religion, color, national origin, age, physical or mental handicap or disability, medical condition, marital status, sex, or sexual orientation, against any employee, applicant for employment, subcontractor, bidder for a subcontract, or participant in, recipient of, or applicant for any services or programs provided by Contractor under this Agreement. Contractor shall comply with all applicable federal, state, and local laws, policies, rules, and requirements related to equal opportunity and nondiscrimination in employment, contracting, and the provision of any services that are the subject of this Agreement, including but not limited to the satisfaction of any affirmative obligations required of Contractor thereby.

Contractor shall include the provisions of this Subsection in any subcontract.

**9.6 No Waiver of Remedies.** Neither the inspection by the City or its agents, nor any order or certificate for payment of money, nor any payment for, nor acceptance of the whole or any part of the Work by the City, nor any extensions of time, nor any positions taken by City or its agents shall operate as a waiver of any provision of this Agreement or the Contract Documents or of any power herein reserved to City or any right to damages herein provided, nor shall any waiver of any breach of this Agreement or of the Contract Documents be held to be a waiver of any other or subsequent breach. All remedies provided in this Agreement and in the Contract Documents shall be taken and construed as cumulative; that is, in addition to each and every other remedy provided in this Agreement and/or the Contract Documents, and the City shall have any and all equitable and legal remedies, which it would in any case have.

**9.7 Governing Law.** This Agreement and the Contract Documents shall be deemed to have been entered into in the County of Contra Costa, State of California, and governed by California law (excluding choice of law rules). By entering into this Agreement, the Contractor consents and submits to the jurisdiction of Courts of the State of California, over any action of law, suit in equity, and/or other proceeding that may arise out of the Contract Documents.

**9.8 Notices.** Except as otherwise specified herein, all notices to be sent pursuant to this Agreement or the Contract Documents shall be made in writing, and sent to the Parties at their respective addresses specified below or to such other address as a Party may designate by written notice delivered to the other parties in accordance with this Section. All such notices shall be sent by:

- A. personal delivery, in which case notice is effective upon delivery;
- B. certified or registered mail, return receipt requested, in which case notice shall be deemed delivered on receipt if delivery is confirmed by a return receipt;
- C. nationally recognized overnight courier, with charges prepaid or charged to the sender's account, in which case notice is effective on delivery if delivery is confirmed by the delivery service;
- D. facsimile transmission, in which case notice shall be deemed delivered upon transmittal, provided that (a) a duplicate copy of the notice is promptly delivered by first-class or certified mail or by overnight delivery, or (b) a transmission report is generated reflecting the accurate transmission thereof. Any notice given by facsimile shall be considered to have been received on the next business day if it is received after 5:00 p.m. recipient's time or on a non-business day.

Any written notice to Contractor shall be sent to:

Company Name Shimmick Construction Company, Inc.  
 Company Address 1 Harbor Center, Suite 200, Suisun City, CA 94585  
 Individual's Name John White  
 Individual's Email Address jwhite@shimmick.com  
 Individual's Direct Dial Phone #: 707-759-6858  
 Individual's Fax # 510-777-5099

Any written notice to City shall be sent to:

City of Antioch  
Capital Improvements Division  
P.O. Box 5007  
Antioch, CA 94531-5007

**9.9 Execution in Counterparts.** This Agreement may be executed in counterparts each of which shall be deemed an original and all of which taken together shall constitute one and the same instrument.

**IN WITNESS WHEREOF**, the parties hereto have signed the Agreement on the date set forth opposite their names.

**CONTRACTOR**

Under penalty of perjury, I certify that the taxpayer identification number and all other information provided here are correct.

DATE: \_\_\_\_\_

BY: \_\_\_\_\_

\_\_\_\_\_  
 Print Name

\_\_\_\_\_  
 Title:

C11

BY \_\_\_\_\_

Print Name

Title: \_\_\_\_\_

1000001063  
DIR Registration #

\_\_\_\_\_  
Federal ID#

\_\_\_\_\_  
State ID#

594575, A, B, C10, C13, C33, C36, C51, HAZ  
California Contractor's License # & Classifications

June 30, 2022  
Contractor's License Expiration Date

Type of Business Entity (*check one*):

- Individual/Sole Proprietor
- Partnership
- Corporation
- Limited Liability Company
- Other (*please specify*: \_\_\_\_\_)

If Contractor is an out-of-state corporation, Contractor warrants and represents that it possesses a valid certificate of qualification to transact business in the State of California issued by the California Secretary of State pursuant to Section 2105 of the California Corporations Code.

**CITY OF ANTIOCH**  
a California Public Entity

DATE: \_\_\_\_\_

BY \_\_\_\_\_  
Rowland E. Bernal, Jr., City Manager

Original Approved as To Form:

Attest:

\_\_\_\_\_  
Thomas Lloyd Smith, City Attorney

\_\_\_\_\_  
Elizabeth Householder, City Clerk

Original Approved as to Form:

\_\_\_\_\_  
John Samuelson, Public Works Director/City Engineer



# ATTACHMENT "D"



200 Parr Boulevard  
Richmond, CA 94801  
Tel 510-234-0926  
Fax 510-237-2435  
www.overaa.com

December 9, 2020

City of Antioch Finance Director  
c/o Scott Buenting, P.E., Project Manager CIP  
Public Works Department  
200 'H' Street, Antioch, CA 94509  
sbuenting@ci.antioch.ca.us

Re: Antioch Brackish Water Desalination Project PW 694  
Protest of Bid of Shimmick

Dear Mr. Buenting:

C. Overaa & Co. hereby protests the bid of Shimmick on the above-referenced project on the grounds that its bid was non-responsive because Shimmick's Marine Prequalification was insufficient, showing only a single past project that meets the specifications when two was required.

Shimmick, because it proposed to split the work between itself and its subcontractor, Lind Marine, was required, pursuant to Addendum 2, to submit references of two projects by the subcontractor for the work proposed to be performed by the subcontractor and two projects by the prime contractor for the scope of work proposed to be performed by the prime contractor. To satisfy the requirement on behalf of itself, Shimmick listed four projects on its bid, but only one of those projects meets the specifications of an applicable project.

Among the criteria for a project to be applicable to the experience requirement set forth in the bid documents are that the project have involved the construction of a cofferdam with at least 3,000 square feet of sheet piling, and that the sheet piles have been at least 40 feet long. Only one of the four projects listed by Shimmick satisfies both criteria.

The four projects listed by Shimmick are the Smith Canal Gate, the Dumbarton Bridge Seismic Retrofit, the Wallace Weir Fish Rescue Facility and the Combined Pumping Plant and Fish Screen Project. Of those four, only two, the South Canal Gate and the Dumbarton Bridge Seismic Retrofit, included the construction of a cofferdam with at least 3,000 square feet of sheet piling. Of those two, the sheet piles on the Dumbarton Bridge Seismic Retrofit were only 25 feet long, not 40 feet long as required by the specifications of this project. Thus, only the Smith Canal Gate project qualifies as an example of applicable experience with which Shimmick can satisfy the experience requirement of this project.



Since it was required that Shimmick have experience with two applicable projects, Shimmick cannot establish it has had the required experience and Shimmick's bid is, therefore, non-responsive.

C. Overaa & Co. respectfully requests that this protest be considered in the decision to award the project.

Please keep us apprised of the progress of this matter, and please inform us if you require further information.

Sincerely,

C. OVERAA & CO.

Joshua Genser

Digitally signed by Joshua Genser  
DN: cn=Joshua Genser, o=Overaa  
Construction, ou=General Counsel,  
email=jgenser@overaa.com, c=US  
Date: 2020.12.09 12:30:26 -08'00'

Joshua Genser  
General Counsel  
C. Overaa & Co.  
200 Parr Blvd  
Richmond, CA 94801  
jgenser@overaa.com

ATTACHMENT "E"



Shimmick Construction Co., Inc.  
1 Harbor Center  
Suite 200  
Suisun City, CA 94585  
Main: 707.759.6858  
[SHIMMICK.COM](http://SHIMMICK.COM)

December 11, 2020

**Via Electronic Mail**

City of Antioch Finance Director  
c/o Scott Buenting, P.E.  
Project Manager CIP  
Public Works Department  
200 H Street, Antioch, California 94509  
[sbuenting@ci.antioch.ca.us](mailto:sbuenting@ci.antioch.ca.us)

Re: Antioch Brackish Water Desalination Project PW 694  
Bid Date: December 2, 2020  
Low Bidder: Shimmick Construction Company, Inc.

Dear Mr. Buenting:

1. Introduction

This is Shimmick Construction Company, Inc.'s ("Shimmick"), response to the protest of C. Overaa & Co. ("Overaa") for the above project ("Project"). As detailed below, Shimmick is the lowest responsive and responsible bidder on the Project and properly identified qualifying projects for the cofferdam element of work it will self-perform. In particular, Shimmick's past cofferdam work significantly exceeds the City's qualification requirements. For this and several additional—and independent—reasons, Shimmick requests the City of Antioch ("City") reject the meritless protest of Overaa and proceed to award the Project to the lowest responsive and responsible bidder: Shimmick.

2. Factual Summary

A. The Project

The Project replaces the City's existing river intake facilities with a new intake pump station and fish screen. It includes three eight (8) million gallons per day pumps, two intake pipelines and fish screens, and a new raw water pipeline approximately 3,000 feet long. To ensure contractor qualifications in accordance with the California Public Contract Code "responsibility" requirement, the City identified qualification requirements in the bid documents. (See Public Contract Code section 1103.) As detailed below, Shimmick meets all such requirements, and is the most qualified and lowest bidder.

E1





Shimmick Construction Co., Inc.  
1 Harbor Center  
Suite 200  
Suisun City, CA 94585  
Main: 707.759.6858  
[SHIMMICK.COM](http://SHIMMICK.COM)

B. Bid Form Qualification Provisions

Attachment L to the bid documents is enclosed at Tab 1 and provided the certification of marine subcontractor's experience and qualification provisions, i.e., disclosures of past work from which the City may evaluate qualifications/bidder responsibility. Attachment L states in relevant part, "[n]one of the requirements herein are to determine pre-qualification to bid on the Project, but are solely for the Owner's evaluation of bids received.... [I]t shall be at the City's sole discretion to determine whether the Marine Subcontractor is deemed qualified to perform the marine work on the Project." (Underlining added.) Thus, the City provided in its bid documents that it would evaluate bidder qualifications in its "sole discretion." Attachment L then provided the following experience provisions:

<p><b>B. MARINE SUBCONTRACTOR MANDATORY MINIMUM EXPERIENCE REQUIREMENTS</b></p> <p>To demonstrate experience, the Marine Subcontractor must provide all information required below demonstrating that the Marine Subcontractor has performed at least two (2) marine construction projects within the last fifteen (15) years where the marine work was located and permitted in the San Francisco Bay Area or the Sacramento-San Joaquin Bay Delta Area (see Delta map below) which included the elements of work listed below. <b>The required work elements don't have to be on the same project.</b> For example, listing two projects that meet the cofferdam requirements and two different projects that meet the dredging/disposal requirements is acceptable.</p> <ol style="list-style-type: none"><li>1. At least 3000 total square feet of steel sheet piling cofferdam of at least 40 foot long piles to protect the workers for marine construction. Total SF measured from top of piles to tip of piles.</li><li>2. Marine work included dredging and upland disposal of material of a minimum of 1,000 cubic yards from San Francisco Bay Area or the Sacramento-San Joaquin Bay Delta.</li></ol>
---

(Highlighting added.) For ease of review, the element of work referenced in No. 1 above will be denoted as "Cofferdam Element," below and the elements of work referenced in No. 2 above will be denoted as "Dredging Element," below. By this provision, the City allowed bidders to list one project that included both work elements.

C. Addendum No. 2 Qualification Provisions

On October 22, 2020, the City issued Addendum No. 2, a copy of which is enclosed at Tab 2, which provided additional qualification language for bidders who would self-perform one work element and subcontract out the other element. Addendum No. 2 states:



Shimmick Construction Co., Inc.  
 1 Harbor Center  
 Suite 200  
 Suisun City, CA 94585  
 Main: 707.759.6858  
 SHIMMICK.COM

3) Section 00400, Bid Form, Attachment L, Certification of Marine Subcontractor's Experience and Qualifications, make the following modifications:

a. Add the following after the third paragraph of Article 1.02.B:

"It is also acceptable for a Bidder to self-perform one of the work elements and subcontract the other work element specified in this section. For example, the two projects that meet the cofferdam requirements can be submitted by a qualified Bidder, while the dredging/disposal requirements can be submitted by a qualified Subcontractor. If the Bidder proposes this work arrangement, the Bidder must demonstrate that the above qualifications are met (two reference projects) for the portion of work they plan to self-perform. The Marine Subcontractor must also need to demonstrate qualifications for the portion of work they will perform (two reference projects). The Bidder must include an attachment to Certification Form L that explains the proposed separation of work responsibilities and provides references. Under the proposed arrangement the bidder would be required to submit a total of four references (two for the Bidder and two for the Marine Subcontractor)."

Summarily, Addendum No. 2 allowed bidders to identify two projects for the element of work it intended to self-perform and two projects from its subcontractor for the element of work the subcontractor would perform. As detailed below, Shimmick listed qualifying projects.

D. Shimmick Submits the Low Bid With Qualifying Projects

The City opened bids on December 2, 2020. Shimmick submitted the lowest responsive bid, as detailed in the following table:

Bidder	Bid	Spread from Shimmick's Low Bid
Shimmick	\$86,689,000.00	--
Overaa	\$89,766,000.00	<b>\$3,077,000.00</b>
Kiewit Infrastructure West Co.	\$90,458,000.00	<b>\$3,769,000.00</b>
Mountain Cascade, Inc.	\$101,368,000.00	<b>\$14,679,000.00</b>

In compliance with Attachment L and Addendum No. 2, Shimmick provided the requisite attachment in its bid confirming it would self-perform the Cofferdam Element and subcontract the Dredging Element to Lind Marine, Inc.<sup>1</sup> Shimmick listed two projects for

<sup>1</sup> Shimmick notes that Lind Marine, Inc. was not required to be listed on Shimmick's subcontractor listing form. Lind Marine, Inc.'s total value of work equated to \$188,000.00, which is well below the listing threshold of \$433,445.00 which is one-half of one percent of Shimmick's bid.

E3





Shimmick Construction Co., Inc.  
1 Harbor Center  
Suite 200  
Suisun City, CA 94585  
Main: 707.759.6858  
[SHIMMICK.COM](http://SHIMMICK.COM)

Lind Marine, Inc. Shimmick then listed four projects in its Attachment L detailing its requisite qualifications for the Cofferdam Element. Shimmick listed the Smith Canal Gate Project ("Smith Canal Project") which included 16,000SF of total sheet piling for cofferdam construction and 50LF of length for steel sheet piling. Shimmick also listed the Dumbarton Bridge Seismic Retrofit Project ("Dumbarton Project"), noting the project included 5,000SF of sheet piling for cofferdam construction and 25LF of steel sheet piling. As detailed below, these projects meet the qualifications standards.

3. Shimmick's Bid Is Responsive And Overaa's Protest Is Without Merit

On December 9, 2020, Overaa protested award to Shimmick alleging Shimmick did not list two projects which included the elements of work called for in the Cofferdam Element. While conceding the Smith Canal Project met the criteria, Overaa claimed the Dumbarton Project did not because the form listed the Dumbarton Project scope as 25LF for steel sheet piling rather than 40LF.

Overaa's argument is without merit for several reasons. First, and foremost, the Dumbarton project far exceeded the criteria of the Cofferdam Element. Shimmick performance on the Dumbarton Project totaled 8,300SF of steel sheet piling for cofferdam construction and 60LF of total length of steel sheet piling for cofferdam construction—greatly exceeding the Cofferdam Element criteria (Shimmick's description of 25LF captured only a portion of the work). Enclosed at Tab 3 are plan sheets confirming these quantities, which Shimmick performed in full. The following pictures taken during construction of the Dumbarton Project also confirm this work:

E4





Shimmick Construction Co., Inc.  
1 Harbor Center  
Suite 200  
Suisun City, CA 94585  
Main: 707.759.6858  
[SHIMMICK.COM](http://SHIMMICK.COM)

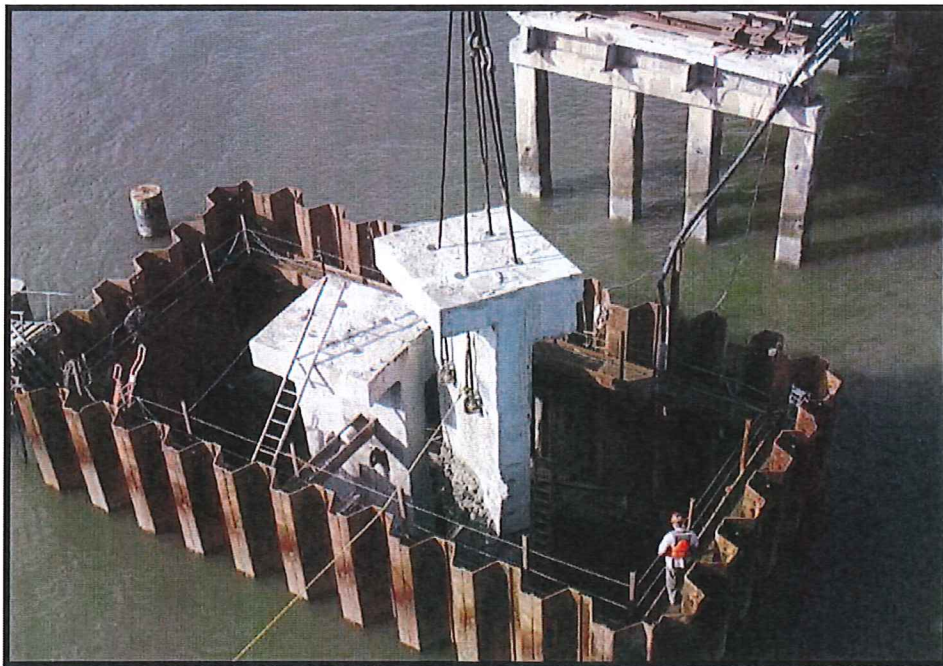



Shimmick Construction Co., Inc.  
1 Harbor Center  
Suite 200  
Suisun City, CA 94585  
Main: 707.759.6858  
[SHIMMICK.COM](http://SHIMMICK.COM)



Shimmicks' bid form, admittedly, did not capture the actual quantities performed on the Dumbarton Project. However, as detailed further below, the inadvertent underselling of the Dumbarton scope is not grounds for protest (let alone justification for spending millions in taxpayer funds on a higher bidder).

Second, Overaa's protest is inconsistent with the City's bid documents, which—consistent with Public Contract Code section 1103—do not categorize the past-project qualification disclosures as bid responsiveness issues. Instead, the City's specifications state, "[n]one of the requirements herein are to determine pre-qualification to bid on the Project, but are solely for the Owner's evaluation of bids received.... [I]t shall be at the City's sole discretion to determine whether the Marine Subcontractor is deemed qualified to perform the marine work on the Project." (Underlining added.) The City has sole discretion to consider Shimmick qualified and award it the Project based on its current Attachment L listing.

Third, to the extent the City believes an issue remains as to Shimmick's qualifications, that issue goes to Shimmick's responsibility as discussed in more detail in Section 4 below. In other words, it has no bearing on whether Shimmick's bid is responsive.

#### 4. Overaa Did Not Raise a Bid Responsiveness Issue

##### A. Responsiveness Versus Responsibility

Overaa mislabels its protest as an attack on the responsiveness of Shimmick's bid. In doing so, it seeks to circumvent the high burden-of-proof and due-process hearing





Shimmick Construction Co., Inc.  
1 Harbor Center  
Suite 200  
Suisun City, CA 94585  
Main: 707.759.6858  
[SHIMMICK.COM](http://SHIMMICK.COM)

necessary to attack Shimmick’s qualifications, i.e., bidder responsibility. California public bidding law distinguishes the two concepts—bid responsiveness and bidder responsibility—and prohibits rejection of a bid as non-responsive based on criteria used to determine bidder responsibility. (See *Great West Contractors, Inc. v. Irvine Unified School Dist.* (2010) 187 Cal.App.4th 1425 [collecting/summarizing public bidding case law].) In *Great West Contractors*, the court detailed the responsiveness/responsibility distinction, beginning with the definition of “responsible bidder” in Public Contract Code section 1103, which states:

“Responsible bidder,” as used in this part, means a bidder who has demonstrated the attribute of trustworthiness, as well as quality, fitness, capacity, and experience to satisfactorily perform the public works contract.

The court then summarized the case law dealing with bid responsiveness, stating, “A bid is responsive if it promises to do what the bidding instructions demand.” (*Great West Contractors, Inc. v. Irvine Unified School Dist.*, *supra*, 187 Cal.App.4th at p. 1452, citing *Taylor Bus Service, Inc. v. San Diego Bd. of Education* (1987) 195 Cal.App.3d 1331, 1341. The Court distinguished the two concepts, stating:

[R]esponsibility is a (1) “complex matter dependent, often, on information received outside the bidding process and requiring, in many cases, an application of subtle judgment” whereas (2) responsiveness is “less complex” and “can be determined from the face of the bid.”

(*Great West Contractors, Inc. v. Irvine Unified School Dist.*, *supra*, 187 Cal.App.4th at pp. 1452-1453.)

**B. Shimmick Is The Lowest Responsive and Responsible Bidder**

Overaa’s protest attacks Shimmick’s qualifications—responsibility—and fails to raise any issue of bid responsiveness. The City’s bid documents identified facts to be considered under both the responsiveness and responsibility examination performed by the City which tracks California law. For example, Article 9.08 of the Instructions to Bidders required bidders to acknowledge all Addenda and that, “failure to do so may result in the bid being rejected as not responsive,” i.e., not promising to do what the bidding instructions require. In contrast, Attachment L provided that the purpose of the qualification provisions was to evaluate, “the requisite quality, fitness, capacity, and experience to perform this important work....” This language echoes the Public Contract Code section 1103 definition of responsibility. As such, Shimmick’s qualifications and experience listed on Attachment L concern only bidder responsibility, and have no bearing on the responsiveness of Shimmick’s bid. Accordingly, Shimmick requests the





Shimmick Construction Co., Inc.  
1 Harbor Center  
Suite 200  
Suisun City, CA 94585  
Main: 707.759.6858  
[SHIMMICK.COM](http://SHIMMICK.COM)

City reject the meritless protest of Overaa and proceed to award the Project to the lowest responsive and responsible bidder: Shimmick.

5. Even if Overaa had Raised a Bid Responsiveness Issue, the City Could and Would Waive It

Even if Overaa had raised a responsiveness issue, the issue could not justify spending millions on a higher bidder, as the issue would be clearly waivable under California law. California public entities may waive bid errors that do not affect price or give the bidder an unfair advantage. (*Valley Crest Landscape, Inc. v. City Council* (1996) 41 Cal.App.4th 1432.) Here, there is no reasonable argument for the notion that Shimmicks' description of past projects could have affected its price or resulted in its competitive advantage (Overaa does not even argue the point).

With respect to waiving such issues, the Court of Appeal in *Ghilotti Construction Co. v. City of Richmond* articulated the approach of California public entities, stating:

These considerations [of bid responsiveness] must be evaluated from a practical rather than a hypothetical standpoint, with reference to the factual circumstances of the case. They must also be viewed in light of the public interest, rather than the private interest of a disappointed bidder. It certainly would amount to a disservice to the public if a losing bidder were to be permitted to comb through the bid proposal or license application of the low bidder after the fact, [and] cancel the low bid on minor technicalities, with the hope of securing acceptance of his, a higher bid. Such construction would be adverse to the best interests of the public and contrary to public policy.

(*Ghilotti Construction Co. v. City of Richmond* (1996) 45 Cal.App.4th 897, 908-909, [internal quotation marks omitted, emphasis added.]) Applying this framework, Overaa cannot reasonably ask the City to pay a \$3 million premium based on a Shimmick's description of its past work.

6. Conclusion

As detailed above, Overaa's protest challenges Shimmick's responsibility to perform the Project, not whether its bid is responsive. Under California law, Overaa's attack has no effect on the responsiveness of Shimmick's bid. Under the facts, Overaa's attack is without merit as Shimmick is clearly the most qualified and responsible bidder. Notably, the City reserved the "sole direction," to determine bidder qualifications pursuant to Attachment L. Finding that Shimmick is qualified to perform the work is a finding of fact that is presumed right under California law. That is because California courts afford

E8



Shimmick Construction Co., Inc.  
1 Harbor Center  
Suite 200  
Suisun City, CA 94585  
Main: 707.759.6858  
[SHIMMICK.COM](http://SHIMMICK.COM)

public agencies wide deference on discretionary determinations such as this. Indeed, as the court in *Bay Cities Paving & Grading, Inc. v. City of San Leandro* (2014) 223 Cal.App.4th 1181, 1187 stated, “[t]here is a presumption that the City’s actions were supported by substantial evidence, and [petitioner/plaintiff] has the burden of proving otherwise. We may not reweigh the evidence and must view it in the light most favorable to the City’s actions, indulging all reasonable inferences in support of those actions.” Accordingly, the facts and California law confirm Shimmick is qualified to perform this Project. Shimmick requests the City reject the meritless protest of Overaa and proceed to award the Project to the lowest responsive and responsible bidder: Shimmick.

Sincerely,

A handwritten signature in black ink, appearing to read "John White", written in a cursive style.

John White  
Executive Vice President, Northwest Division Shimmick  
Shimmick Construction Company, Inc.

cc: Shimmick Construction Company, Inc. (via email only)  
Attn: Gregory J. Dukellis, Esq., General Counsel  
John White, Vice President, Northwest Region  
Jason Burden, Estimator  
CDM Smith  
Attn: Jeffrey J. Sellberg, P.E. (via email only)  
City of Antioch  
Attn: Mr. John Samuelson, Public Works Director (via email only)

# TAB 1



## ATTACHMENT L

CERTIFICATION OF MARINE SUBCONTRACTOR'S  
EXPERIENCE AND QUALIFICATIONS

(To Be Submitted no later than 3 p.m. the day Bids are due)

PROJECT: City of Antioch Brackish Water Desalination Project

**Important Note:** To be eligible for an award of Contract, the Bidder must submit to City this signed Certification from the Marine Subcontractor listed on Bidder's DESIGNATION OF SUBCONTRACTORS. If the Bidder does not list a Marine Subcontractor for the construction of any portion of the new 48" fish screens, 42" raw water pipeline and related cofferdams to construct these new facilities within the San Joaquin River, then Bidder must submit to City with its Bid this signed Certification of Bidder's experience and qualifications to self-perform the marine work with the understanding that all references to Marine Subcontractor in this certification shall mean Contractor, and Contractor shall possess independently the minimum standards of experience and qualifications set forth below. The Owner has determined that only Marine Subcontractors meeting these mandatory minimum experience and qualification requirements will have the requisite quality, fitness, capacity and experience to perform this important and critical marine work on this Project. Failure of the Marine Subcontractor or Bidder to meet or comply with the requirements of this certification, including, but not limited to, the mandatory minimum experience requirements and qualifications required herein, may be grounds for the Owner to determine the Bidder as non-responsive and/or non-responsible and ineligible for contract award. None of the requirements herein are to determine pre-qualification to bid on the Project, but are solely for the Owner's evaluation of bids received. Notwithstanding anything contained in this Attachment L, it shall be at the City's sole discretion to determine whether the Marine Subcontractor is deemed qualified to perform the marine work on the Project.

The undersigned Marine Subcontractor certifies that it is, at the time of bidding, and shall be, throughout the period of the contract, licensed under the provisions of Chapter 9, Division 3, of the Business and Professions Code of the State of California, to do the type of work contemplated in the Contract Documents. The Marine Subcontractor shall further certify that it is skilled and regularly engaged in the general class and type of work called for in the Contract Documents.

The Marine Subcontractor represents that it is competent, knowledgeable, and has special skills on the nature, extent, and inherent conditions of the work to be performed. The Marine Subcontractor further acknowledges that there are certain peculiar and inherent conditions existent in the construction of the particular facilities which may create, during the construction program, unusual or peculiar unsafe conditions hazardous to persons and property. The Marine Subcontractor expressly acknowledges that it is aware of such peculiar risks and that it has the skill and experience to foresee and to adopt and implement protective measures to adequately and safely perform the construction work with respect to such hazards.

If the Marine Subcontractor is a Joint Venture of two or more companies, each participant in the Joint Venture shall separately complete this ATTACHMENT L, CERTIFICATION OF MARINE SUBCONTRACTOR'S EXPERIENCE AND QUALIFICATIONS and each participant shall meet the mandatory prior company project experience requirement and provide project information for each Joint Venture participant in the format found below.

**A. QUESTIONS REGARDING MARINE SUBCONTRACTOR'S RESPONSIBILITY AND FITNESS TO SUBCONTRACT FOR THE MARINE WORK.**

If Marine Subcontractor answers "Yes" to any of Questions 1 through 7 below, the Marine Subcontractor must provide on a separate sheet a complete, detailed explanation of all of the facts and circumstances concerning the reasons for answering "Yes", and shall provide documentation supporting its response.

E11

8. Has your company's contractor's license(s) been revoked at any time in the last five years?
- Yes       No
9. Within the last five years, has a surety company completed a contract on your company's behalf, or paid for the completion of a contract to which your firm was a party, because your firm was considered to be in default or was terminated with cause by the project owner?
- Yes       No
10. At the time of submitting this Certification of Marine Subcontractor's Experience and Qualifications, is your company ineligible to bid on or be awarded a public works contract, or perform as a subcontractor on a public works contract, pursuant to either California Labor Code section 1777.1 or Labor Code section 1777.7?
- Yes       No
11. At any time in the last five years, has your company, or any of its owners, officers or partners been convicted of a crime involving the awarding of a contract for a government construction project, or the bidding or performance of any federal, state or local government contract?
- Yes       No
12. Has your company or any of its owners, officers or partners ever been found liable in a civil suit for making any false claim or material misrepresentation to any federal, state or local public agency or entity?
- Yes       No
13. In the last five years has your company been denied an award of a public works contract based on a finding by any federal, state or local public agency that your firm was not a responsible Bidder?
- Yes       No
14. In the last three years has your company been debarred from bidding on, or completing, any government agency or public works construction contract for any reason?  
NOTE: If there is a pending administrative or court action challenging a debarment, you need not include that debarment in responding to this question.
- Yes       No

#### B. MARINE SUBCONTRACTOR MANDATORY MINIMUM EXPERIENCE REQUIREMENTS

To demonstrate experience, the Marine Subcontractor must provide all information required below demonstrating that the Marine Subcontractor has performed at least two (2) marine construction projects within the last fifteen (15) years where the marine work was located and permitted in the San Francisco Bay Area or the Sacramento-San Joaquin Bay Delta Area (see Delta map below) which included the elements of work listed below. The required work elements don't have to be on the same project. For example, listing two projects that meet the cofferdam requirements and two different projects that meet the dredging/disposal requirements is acceptable.

1. At least 3000 total square feet of steel sheet piling cofferdam of at least 40 foot long piles to protect the workers for marine construction. Total SF measured from top of piles to tip of piles.
2. Marine work included dredging and upland disposal of material of a minimum of 1,000 cubic yards from San Francisco Bay Area or the Sacramento-San Joaquin Bay Delta.



The Marine Subcontractor can include project(s) currently under construction, but only if the above type of cofferdam and dredging has been completed and paid by the owner. Any projects listed below which are not as defined above will not be considered by the City in meeting this minimum experience requirement.

The Marine Subcontractor also certifies that it self-performed with its own labor force at least fifty percent (50%) of the marine work on each of the projects listed below. The City considers this level of past self-performance demonstrates a benefit to a Project in terms of better control of cost, schedule and safety.

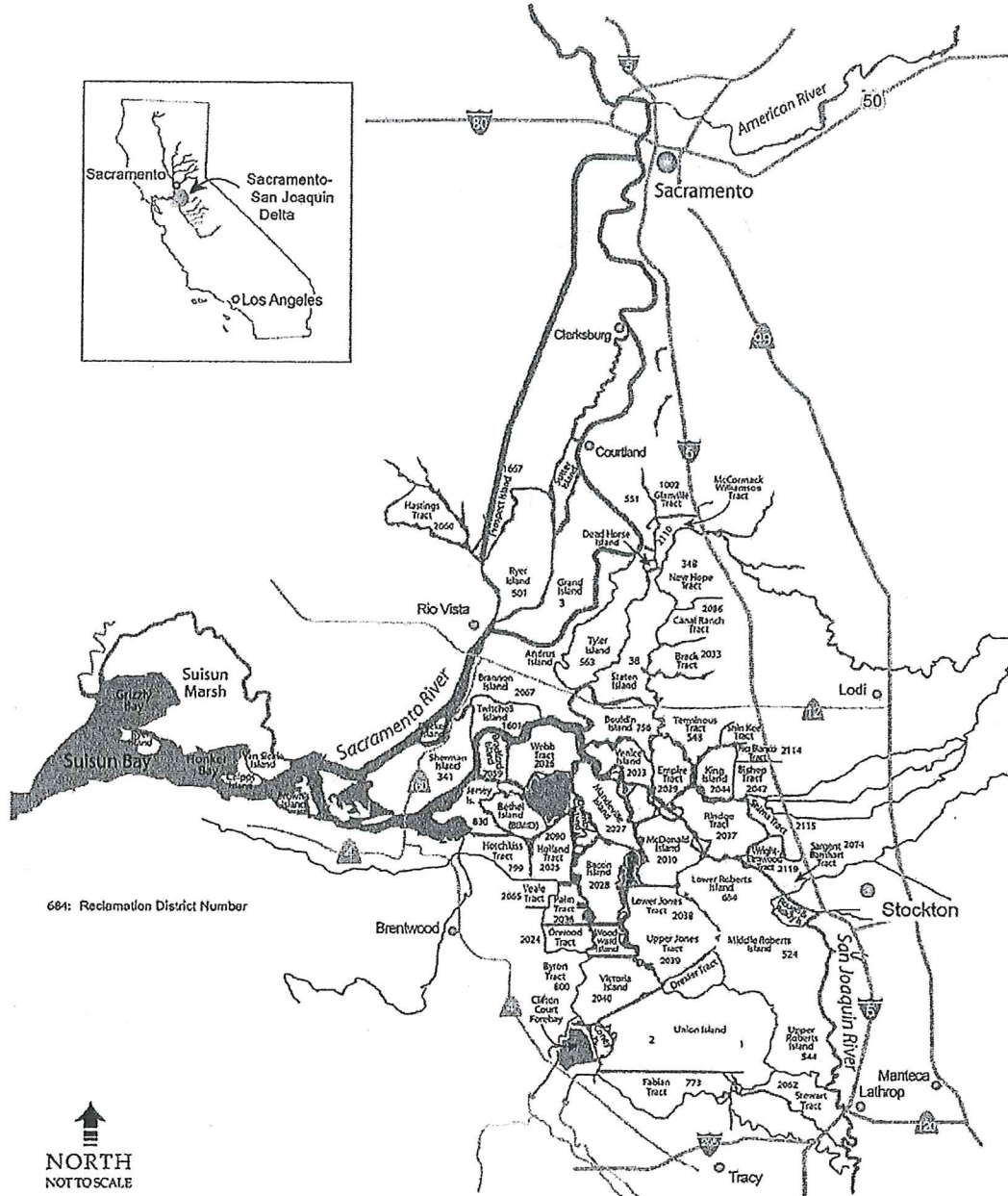

E13



Bidders are to complete this form and not attach their own form to the Bid Form.

Project #1 Name: \_\_\_\_\_

Owner: \_\_\_\_\_

Project location: \_\_\_\_\_

Total SF of Steel Sheet Piling for Cofferdam Construction: \_\_\_\_\_ SF

Total Length of Steel Sheet Piling for Cofferdam Construction: \_\_\_\_\_ LF

Total Cubic Yards of Dredged and Upland Disposed Soils: \_\_\_\_\_ CY

Owner's Representative: \_\_\_\_\_

Owner's Representative Telephone No.: \_\_\_\_\_

Engineer or On-Site Construction Manager: \_\_\_\_\_

Engineer or On-Site Construction Manager Telephone No.: \_\_\_\_\_

Date of Substantial Completion: \_\_\_\_\_ (must be within last 6 years)

Project #2 Name: \_\_\_\_\_

Owner: \_\_\_\_\_

Project location: \_\_\_\_\_

Total SF of Steel Sheet Piling for Cofferdam Construction: \_\_\_\_\_ SF

Total Length of Steel Sheet Piling for Cofferdam Construction: \_\_\_\_\_ LF

Total Cubic Yards of Dredged and Upland Disposed Soils: \_\_\_\_\_ CY

Owner's Representative: \_\_\_\_\_

Owner's Representative Telephone No.: \_\_\_\_\_

Engineer or On-Site Construction Manager: \_\_\_\_\_

Engineer or On-Site Construction Manager Telephone No.: \_\_\_\_\_

Date of Substantial Completion: \_\_\_\_\_ (must be within last 6 years)

Project #3 Name: \_\_\_\_\_

Owner: \_\_\_\_\_

Project location: \_\_\_\_\_

Total SF of Steel Sheet Piling for Cofferdam Construction: \_\_\_\_\_ SF

E14

Total Length of Steel Sheet Piling for Cofferdam Construction: \_\_\_\_\_ LF

Total Cubic Yards of Dredged and Upland Disposed Soils: \_\_\_\_\_ CY

Owner's Representative: \_\_\_\_\_

Owner's Representative Telephone No.: \_\_\_\_\_

Engineer or On-Site Construction Manager: \_\_\_\_\_

Engineer or On-Site Construction Manager Telephone No.: \_\_\_\_\_

Date of Substantial Completion: \_\_\_\_\_ (must be within last 6 years)

Total Construction Volume of listed Project(s) above: \$ \_\_\_\_

**Important Note: Any projects found on Marine Subcontractor's completed projects list which are not as defined above will not be considered by the City in meeting this experience requirement. It is very important that Marine Subcontractor provide current and valid project contact information for all projects listed above. All information should be checked for accuracy before completing this Attachment.**

**C. BONDING PROFILE**

At the time of submission of the bid the Marine Subcontractor shall have an unencumbered bonding capacity equal to at least 100 percent of the Marine Subcontract cost for this project.

Current Total Bonding Capacity: \_\_\_\_\_

Current Unencumbered Bonding Capacity: \_\_\_\_\_

To verify the above information, the Owner will contact the Marine Subcontractor's surety. The Marine Subcontractor shall authorize its surety to release this information.

Surety: \_\_\_\_\_

Contact Person for Insurance Company: \_\_\_\_\_

Telephone Number: \_\_\_\_\_

Signed this \_ day of \_\_, 20 \_\_\_\_.

If the Bidder (Contractor) is satisfied with the financial capability and capacity of the Marine Subcontractor as required for the performance of the work on the Project, the Bidder may indicate such by signing below and the Marine Subcontractor will in such case not be required to provide the bonding information listed above.

Bidder acknowledgement of Marine Subcontractor's financial capability and capacity and waiver of bond information:

\_\_\_\_\_

E15

Name of Bidder

Date

\_\_\_\_\_  
Bidder, Signature

\_\_\_\_\_  
Printed Name of person's Signature

**MARINE SUBCONTRACTOR VERIFICATION AND SIGNATURE**

I, the undersigned, certify and declare that I have read all the foregoing answers to this Statement of Qualifications Questionnaire. I also certify and declare that I have personally reviewed and approved the information provided for the Company Experience Information. I certify and declare that the foregoing is true and correct.

Signed this \_\_\_\_\_ day of \_\_\_\_\_, 20\_\_\_\_

\_\_\_\_\_  
Marine Subcontractor's Name

\_\_\_\_\_  
Authorized Signature

\_\_\_\_\_  
Date:

\_\_\_\_\_  
Title of Signator

\_\_\_\_\_  
Valid CA Contractors License No.

\_\_\_\_\_  
License Classification

\_\_\_\_\_  
Expiration Date

**END OF ATTACHMENT L**

E16



# TAB 2

**ANTIOCH**  
**CALIFORNIA**  
OPPORTUNITY LIVES HERE

**ADDENDUM NO. 2**  
**TO THE**  
**CONTRACT DOCUMENTS**

**FOR**

**BRACKISH WATER DESALINATION PROJECT**  
**P.W. 694**

**ISSUED**  
**October 22, 2020**

Bidders shall acknowledge receipt of this Addendum and all other Addenda issued by the City in Article II of the Bid Form, Section 00400. A Bid may be deemed non-responsive if receipt of all Addenda issued by the City are not acknowledged.

SEE ATTACHED ADDENDUM ITEMS

Approved By:

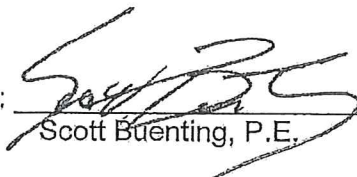
  
Scott Buenting, P.E.



## ADDENDUM NO. 2

### Brackish Water Desalination Project PW 694

Issued October 22, 2020

- 1) Section 00100, Notice Inviting Bids, Paragraph 4.02.B, replace the first paragraph with the following:

"B. In addition to the above mandatory requirements, all Bidders must visit the Project Sites prior to submitting their sealed Bid. Bidders must do so by appointment only. **Appointments for site visits to all three Project Sites are available only on Tuesday October 27, 2020 starting at 9 a.m., Wednesday October 28, 2020 starting at 1 p.m., and Thursday November 5, 2020 starting at 9 a.m. Site tours will start at the River Pump Station, then to Antioch WTP, and then conclude at Delta Diablo WWTP. Visits for Subcontractors that are only interested in the Water Treatment Plant and/or River Pump Station sites are available by appointment on Thursday October 29, 2020, Tuesday November 3, 2020 and Wednesday November 4, 2020 between 9 a.m. and 3 p.m.** The size of groups for each site visit will be limited to twenty persons. The tours for all three Project Sites is anticipated to last approximately two hours. To schedule an appointment, please contact Scott Weddle at [sweddle@carollo.com](mailto:sweddle@carollo.com) or 925-949-6486. Bidders will acknowledge meeting this mandatory requirement where indicated in Section 00400, Bid Form. Site visits are not mandatory for Subcontractors, but Subcontractors may also visit the Project Sites on the days noted above by appointment only."

- 2) Section 00400, Bid Form, Attachment I, in paragraph B.2 under "Project Manager Experience", modify the last sentence as follows:

"The demonstrated experience of the Project Manager must have demonstrated within the last fifteen (15) years."

- 3) Section 00400, Bid Form, Attachment L, Certification of Marine Subcontractor's Experience and Qualifications, make the following modifications:

- a. Add the following after the third paragraph of Article 1.02.B:

"It is also acceptable for a Bidder to self-perform one of the work elements and subcontract the other work element specified in this section. For example, the two projects that meet the cofferdam requirements can be submitted by a qualified Bidder, while the dredging/disposal requirements can be submitted by a qualified Subcontractor. If the Bidder proposes this work arrangement, the Bidder must demonstrate that the above qualifications are met (two reference projects) for the portion of work they plan to self-perform. The Marine Subcontractor must also need to demonstrate qualifications for the portion of



work they will perform (two reference projects). The Bidder must include an attachment to Certification Form L that explains the proposed separation of work responsibilities and provides references. Under the proposed arrangement the bidder would be required to submit a total of four references (two for the Bidder and two for the Marine Subcontractor)."

- b. Modify the last line of each project reference in Article 1.02.B as follows:

"Date of Substantial Completion \_\_\_\_\_ (must be within last 15 years)"

- 4) Section 00451G, Pipeline Rehabilitation Qualification Form, delete this Section in its entirety.

- 5) Section 01146, Use of Site, replace paragraph 1.02.H with the following:

"The Contractor is not allowed to use or operate any City owned tools or equipment at any time during the Contract, except as follows: The Contractor may use the existing elevator at Plant A for transporting valves and equipment into and out of the filter gallery. The weight limit of 4,000 pounds shall not be exceeded. No personnel are allowed to ride in the elevator. Contractors shall complete safety training provided by the City prior to using the elevator."

- 6) Section 01500, Temporary Facilities and Controls, make the following changes:

- a. Paragraph 1.03.B.1, replace as follows:

"B. Site Plan:

1. The Contractor shall submit to the Construction Manager for review its proposed plan and layout for all field offices, site access, security, security lighting, staging areas, storage areas, employee, subcontractor and craft labor parking, water sources (potable and non-potable), construction water storage, temporary electrical power, telephone source location and distribution, and high-speed internet connectivity:

- a. The proposed plan shall include a field office complex where all of the participants are adjacent to each other for enhanced communication with each other. The field office complex shall include a double-wide trailer to serve as the joint-use conference room allowing for social distancing for the project management team to utilize for daily meetings, weekly project meetings, special meetings, and training sessions. The individual offices shall be connected to the other field offices by an elevated, covered, wood deck. Entrances to each office door shall include a grate with non-potable washdown hose bib and boot brushes to wash off mud on the boots before entering the offices."

b. Paragraph 1.07.A, replace as follows:

"General:

1. The Contractor shall erect construction entrance signs and one-way signs along access roads to direct construction traffic into and out of the sites safely.
2. If additional access roads are needed around the construction site the Contractor shall build and maintain access roads to and on site of the work to provide for delivery of material and for access to existing and operating plant facilities on site."

c. Paragraph 01500-1.10.B.1.b, delete in its entirety.

### SELECTED RESPONSES TO REQUESTS FOR INFORMATION

- 1) **Question:** "I've been reviewing the prevailing wage determinations linked in the Notice to Contractors for this project and I noticed that the Northern California Laborers scope description (found here: <https://www.dir.ca.gov/oprl/2020-2/PWD/Scope/Northern/NC-023-102-1-Sco.pdf>) does not include water treatment piping as it's called out in the full 2018-2023 AGC/Laborers Master Agreement, which is as follows: "All mechanical and pressurized pipe work, including the laying and installation of pipe above and below ground, cathodic protection, bolt up, and support installation in connection to water conveyance, purification, filtration, and treatment facilities." Not sure if you're the one to answer this, but does this mean that the Pipefitter prevailing wage will need to be used for the mechanical piping work?"

**Answer:** The applicable classification for a particular work process will be determined by the scope of work description in the applicable Prevailing Wage Determination, not by the craft work description in a craft's Master Labor Agreement. For the work in question as we understand your question, please review the scope descriptions for the individual worker classifications found in the following prevailing wage determination link: <https://www.dir.ca.gov/oprl/2020-2/PWD/index.htm> for Contra Costa County (Step 4) under the "Plumber" classification of the determination. All scope descriptions should be reviewed for the various individual worker classifications to be sure you have identified the applicable classification and corresponding wage/fringe requirements.

- 2) **Question:** Will CAD files be made available to bidders during the bid period?

**Answer:** No. CAD files will not be made available to Bidders.

# TAB 3



GENERAL NOTES:

GENERAL

1. PERFORM ALL WORK IN ACCORDANCE WITH APPLICABLE BUILDING CODES AND SAFETY REGULATIONS INCLUDING THE PROVISIONS OF CAL-OSHA AND FEDERAL OSHA.
2. BLCE WILL NOT SUPERVISE, DIRECT, CONTROL, OR HAVE AUTHORITY OVER OR BE RESPONSIBLE FOR CONTRACTOR'S MEANS, METHODS, TECHNIQUES, OR THE SAFETY PRECAUTIONS AND PROGRAMS INCIDENT TO THE WORK, OR WITH ANY FAILURE OF CONTRACTOR TO COMPLY WITH APPLICABLE LAWS AND REGULATIONS PERTAINING TO THE PERFORMANCE OF THE WORK. UNLESS NOTED OTHERWISE, BLCE WILL NOT SUPERVISE, DIRECT, CONTROL, OR HAVE AUTHORITY OVER OR BE RESPONSIBLE FOR CONTRACTOR'S SEQUENCES OR PROCEDURES OF CONSTRUCTION.
3. VERIFY ALL DIMENSIONS AND ELEVATIONS PRIOR TO ORDERING, FABRICATING OR INSTALLING ANY OF THE ITEMS SHOWN ON THESE DRAWINGS. IF DISCREPANCIES ARE NOTED, NOTIFY BLCE SO THAT APPROPRIATE REVISIONS CAN BE MADE TO THE SHORING DESIGN.
4. PERFORM WELDING IN ACCORDANCE WITH AWS D1.1.
5. PROVIDE SEALANT AT SHEET PILE INTERLOCKS.
6. SEE SHEETS CD-6 AND CD-7 FOR COFFERDAM CONSTRUCTION SEQUENCE.
7. ALL ELEVATIONS USED ON THESE DRAWINGS ARE RELATIVE TO MEAN SEA LEVEL (MSL).

MATERIALS:

1. SHEET PILE: ASTM A572, GRADE 50.
2. WIDE FLANGE: ASTM A992 OR A572, GRADE 50.
3. HP: ASTM A572, GRADE 50.
4. OTHER MISCELLANEOUS STEEL: ASTM A36.
5. TREMIE CONCRETE:  $f_c = 4000$  PSI, MINIMUM AT 28 DAYS.
6. SHEET PILE INTERLOCK SEALANT: ADEKA ULTRA SEAL A-30, OR EQUIVALENT.
7. ADHESIVE ANCHORS: ASTM A193 B7 THREADED ROD ANCHORED WITH HILTI HIT-RE 500 EPOXY ADHESIVE. INSTALL IN ACCORDANCE WITH MANUFACTURER'S INSTRUCTIONS.
8. NON-SHRINK GROUT: SIKAGROUT 212, OR EQUAL.

DESIGN CRITERIA

1. MAXIMUM HIGH WATER LEVEL = ELEVATION +5.
2. MAXIMUM STORM WAVE HEIGHT = 3 FEET WITH ADDITIONAL 1.5 FOOT RUNUP ASSUMED.
3. TOP OF 5-FOOT THICK TREMIE CONCRETE SEAL PLACED AROUND PERIMETER OF EXISTING PIER 1 FOUNDATION NO LOWER THAN ELEVATION -29.
4. DEMOLITION OF PIER 1 FOUNDATION TO NO LOWER THAN ELEVATION -29.
5. STEEL MEMBERS SIZED USING ALLOWABLE STRENGTH DESIGN (ASD) PER AISC "STEEL CONSTRUCTION MANUAL" THIRTEENTH EDITION.

		ORDER <b>STATE OF CALIFORNIA</b> <b>DEPARTMENT OF TRANSPORTATION</b>	CLIENT 			<b>DUMBARTON BRIDGE</b> <b>SEISMIC RETROFIT</b> <b>RAVENSWOOD PIER</b> <b>COFFERDAM AT PIER 1</b> NOTES	SHEET <b>CD-1</b>	
		GRAPHIC SCALE 	DESIGNED: ESL    CHECKED: DJB    DRAWN: HC		CONTRACT: CU 04253    DATE: MAY 7, 2012    JOB: 10030		QUANTITY: 1 OF 7 REVISION: 0 SCALE: 3/4" = 1'-0"	
NO.	DATE	REVISIONS	BY	CK	CADD FILE NAME 10030_CD1.DWG	PLOT DATE	APPROVAL	DATE

223

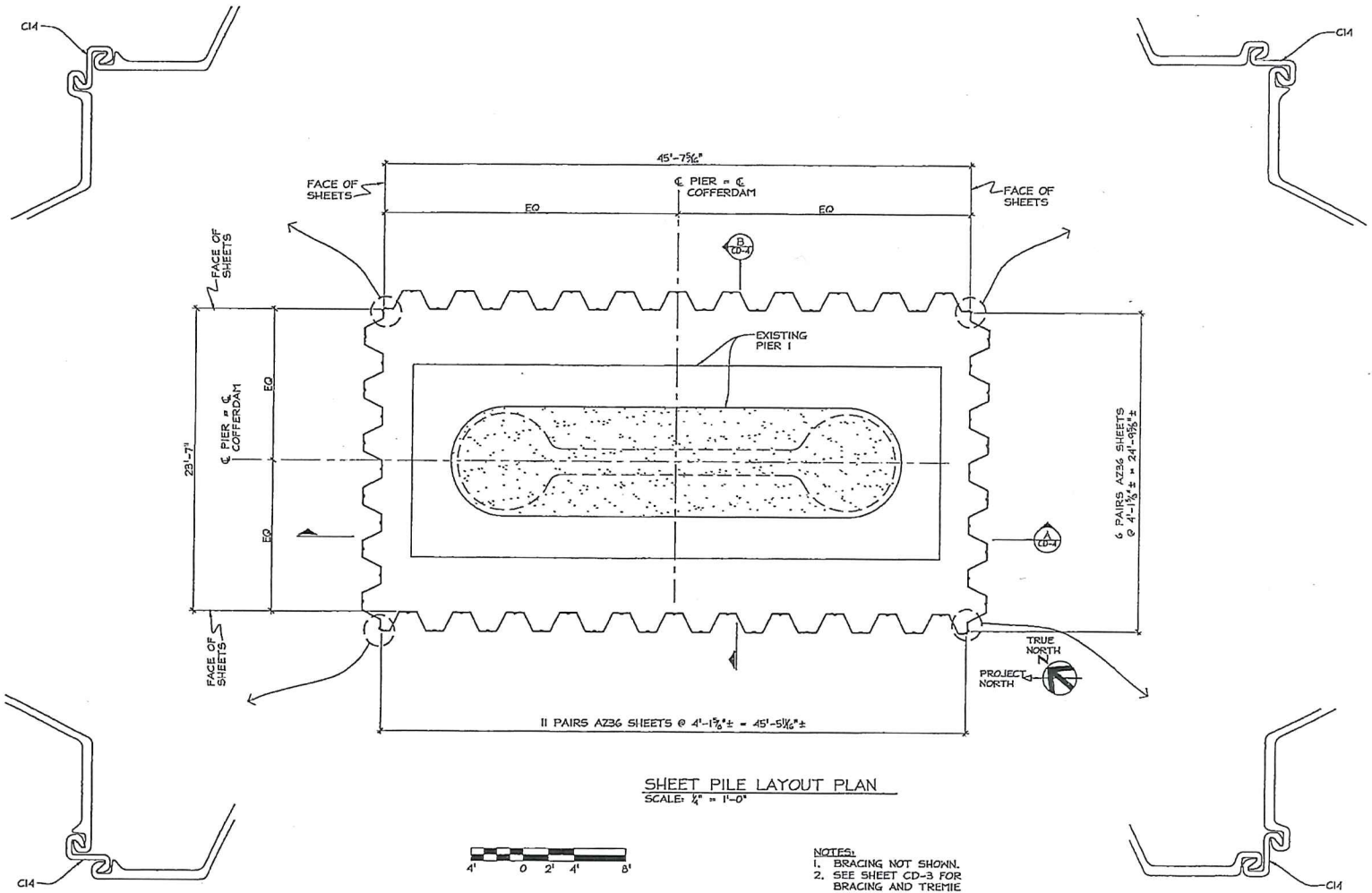

**SHEET PILE LAYOUT PLAN**  
SCALE: 1/4" = 1'-0"

- NOTES:**  
 1. BRACING NOT SHOWN.  
 2. SEE SHEET CD-3 FOR BRACING AND TREMIE CONCRETE

NO.		DATE	REVISIONS	BY	CK	OWNER STATE OF CALIFORNIA DEPARTMENT OF TRANSPORTATION	CLIENT <b>SHIMMICK CONSTRUCTION</b>	DESIGNER <b>BLCE</b> BENTLEY ENGINEERING CONSULTANTS, INC. 1000 RAY GARDENWAY, SUITE 100, SAN JOSE, CA 95128 (415) 241-9025 FAX (415) 241-9010 a Division of Briarley Associates, Inc.	PROFESSIONAL ENGINEER NO. 056713 EXP. 8/31/11 CIVIL STATE OF CALIFORNIA	PROJECT DUMBARTON BRIDGE SEISMIC RETROFIT RAVENSWOOD PIER COFFERDAM AT PIER 1 SHEET PILE LAYOUT PLAN	SHEET CD-2 DRAWING NO. 2 OF 7 REVISION 0					
GRAPHIC SCALE: 0 5' 1" 10" 2" 25' 3"						CADD FILE NAME 10030_CD2.DWG	PROJECT DATE	APPROVED	DATE	DESIGNED ESL	CHECKED DJB	DRAWN HIC	CONTRACT CU 04253	DATE MAY 7, 2012	JOB 10030	SCALE 1/4" = 1'-0"

CD-2

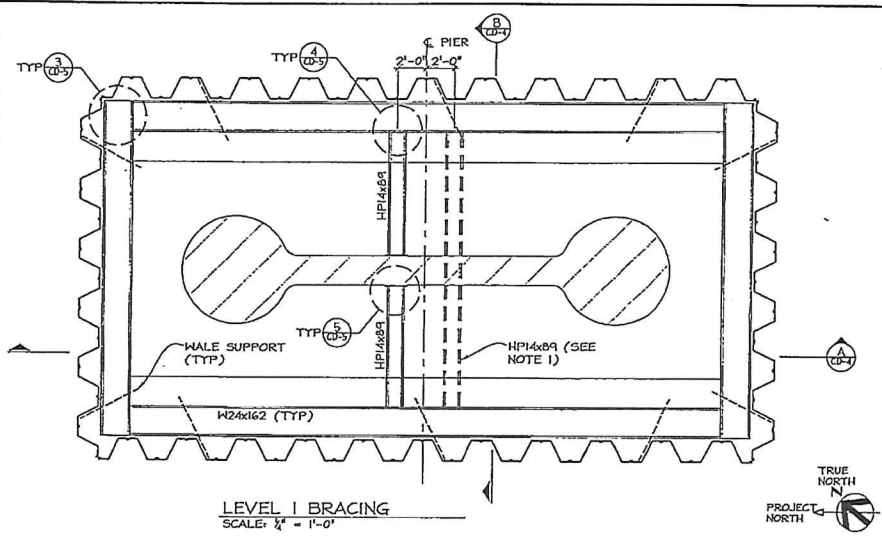

- NOTES:
1. STRUT INSTALLED AFTER PIER PARTIALLY DEMOLISHED. SEE CONSTRUCTION SEQUENCE.
  2. SEE 1/CD-5 FOR TYPICAL SHIM PACKING.
  3. SEE 2/CD-5 FOR TYPICAL WALE SUPPORT.

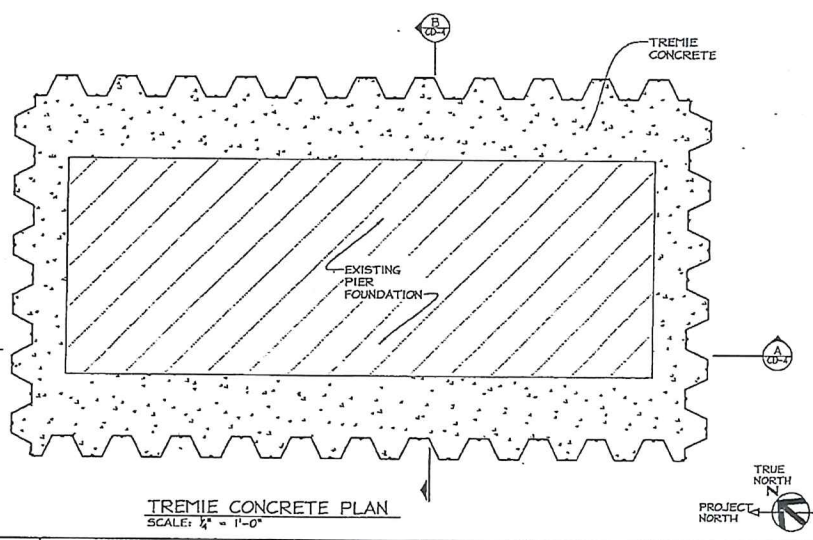
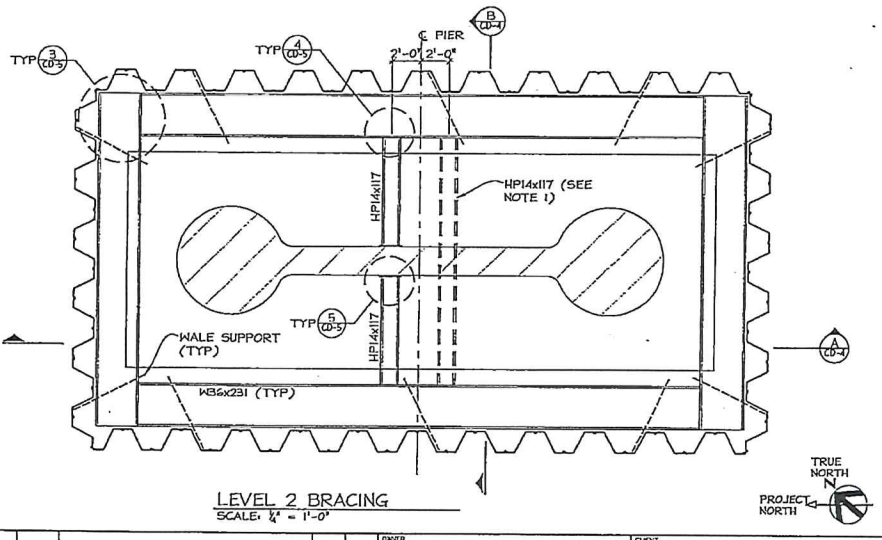

NO.		DATE	REVISIONS	BY	CK	DESIGNER STATE OF CALIFORNIA DEPARTMENT OF TRANSPORTATION GROUP SCALE 0" 1" 1 1/2" 2" 3" 3 1/2"	CLIENT SHIMMICK CONSTRUCTION 10000 10030	APPROVED DATE	DESIGNER BLCE BRILEY CONSULTING ENGINEERS, INC. 220 CALIFORNIA CLUB DRIVE, SUITE 2A, FORTY PALM CA, 91306 (818) 714-0000 FAX (818) 714-0009 a Division of Brerley Associates, Inc.	REGISTERED PROFESSIONAL ENGINEER NO. 656713 EXP. 6-30-13 STATE OF CALIFORNIA	CONTRACT CU 04253 DATE MAY 7, 2012 JOB 10030	SHEET CD-3 DRAWING NO. 3 OF 7 REVISION 0 SCALE 1/4" = 1'-0"
-----	--	------	-----------	----	----	---	--	------------------	---	---	---	--

625



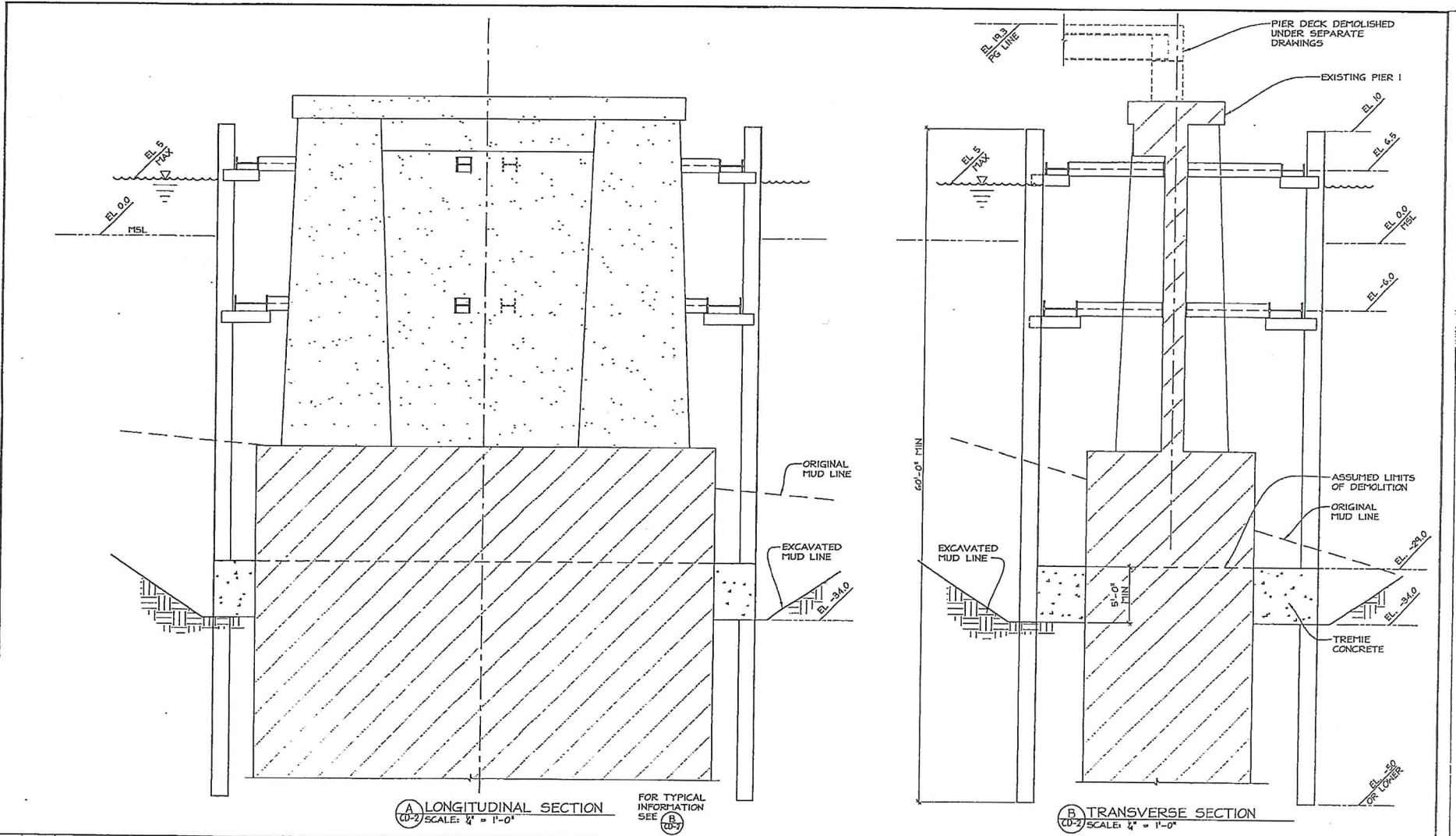

**A** LONGITUDINAL SECTION  
SCALE: 1/4" = 1'-0"

FOR TYPICAL INFORMATION SEE (B)

**B** TRANSVERSE SECTION  
SCALE: 1/4" = 1'-0"

NO.		DATE		REVISIONS		BY		CK		OWNER STATE OF CALIFORNIA DEPARTMENT OF TRANSPORTATION	CLIENT <b>SHIMMICK CONSTRUCTION</b>	DESIGNED ESL		CHECKED D.B		DRAWN HC		<b>BLCE</b> BERTH & HANCOCK ENGINEERING, INC. 550 WESTBURY CLUB DRIVE, GAITHERSBURG, MARYLAND 20878 (301) 241-9900 FAX (301) 241-9919 a Division of Brerley Associates, Inc.	REGISTERED PROFESSIONAL ENGINEER NO. 056713 EXP. 6-30-13 STATE OF CALIFORNIA	DUMBARTON BRIDGE SEISMIC RETROFIT RAVENSWOOD PIER COFFERDAM AT PIER 1 SECTIONS		SHEET <b>CD-4</b>	
DRAWING NO.		4 OF 7		REVISIONS		0		SCALE		1/4" = 1'-0"		CONTRACT		CU 04253		DATE				MAY 7, 2012		JOB	

CD-4

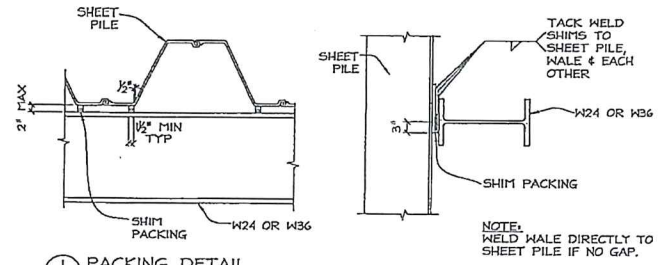

1 PACKING DETAIL  
 (CD-3) SCALE: 3/4" = 1'-0"

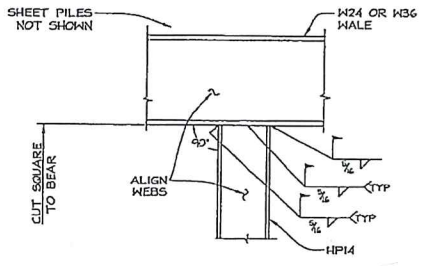

4 TYPICAL STRUT CONNECTION  
 (CD-3) SCALE: 3/4" = 1'-0"

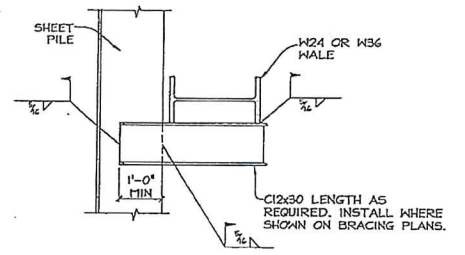

2 WALE SUPPORT BRACKET  
 (CD-3) SCALE: 3/4" = 1'-0"

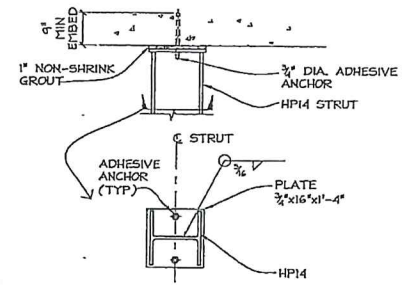

5 STRUT TO PIER CONNECTION  
 (CD-3) SCALE: 3/4" = 1'-0"

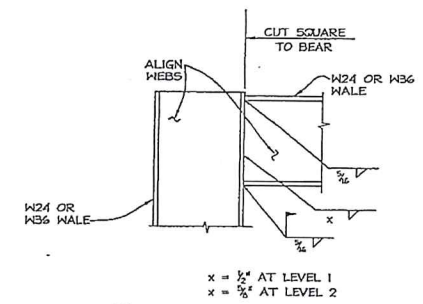

3 TYPICAL CORNER CONNECTION  
 (CD-3) SCALE: 3/4" = 1'-0"

OWNER STATE OF CALIFORNIA DEPARTMENT OF TRANSPORTATION		CLIENT <b>SHIMMICK</b> CONSTRUCTION		 BLCE HEALTH, ENVIRONMENT & CONSTRUCTION CONSULTING ENGINEERS, INC. 250 COUNTY CENTER DRIVE, SUITE 200, SAN ANTONIO, TEXAS 78203 (214) 343-6220 FAX (214) 343-7893 a Division of Bratton Associates, Inc.		 REGISTERED PROFESSIONAL ENGINEER NO. 056713 CIV. E.-38-33 STATE OF CALIFORNIA		DUMBARTON BRIDGE SEISMIC RETROFIT RAVENSWOOD PIER COFFERDAM AT PIER 1 DETAILS		SHEET <b>CD-5</b> DRAWING TITLE 5 OF 7 REVISION 0					
NO.	DATE	REVISIONS	BY	CK	DWG FILE NAME 10030_CDS.DWG	PRINT DATE	APPROVED	DATE	DESIGNED ESL	CHECKED DJB	DRAWN HC	CONTRACT CU 04253	DATE MAY 7, 2012	JOB 10030	SCALE 3/4" = 1'-0"

E27

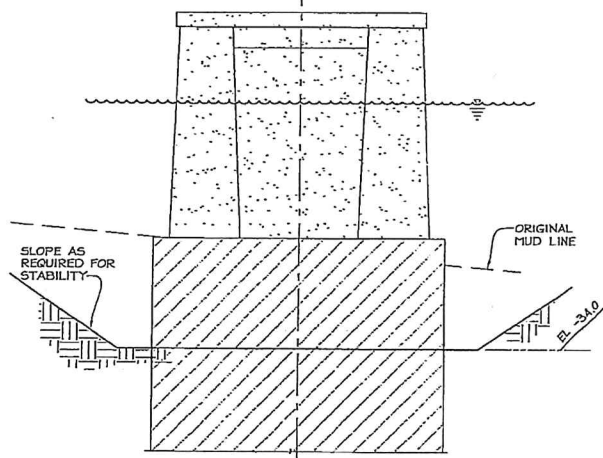

**STAGE 1:**  
 1. EXCAVATE TO ELEVATION -34 (BOTTOM OF TREMIE CONCRETE ELEVATION) WITHIN FOOTPRINT OF COFFERDAM. EXCAVATE A SUFFICIENT AMOUNT OF MATERIAL SO THAT SLOPES ARE STABLE.

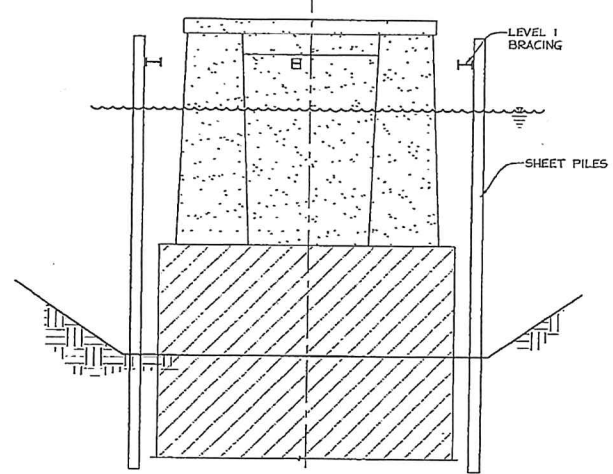

**STAGE 2:**  
 1. INSTALL LEVEL 1 BRACING AS TEMPLATE FOR COFFERDAM SHEET PILES. SUPPORT BRACING MEMBERS USING PIN PILES AS NECESSARY.  
 2. DRIVE SHEET PILES. PROVIDE A HYDRAULIC CONNECTION THROUGH SHEET PILES SO THAT THE WATER LEVEL INSIDE AND OUTSIDE THE COFFERDAM IS ALWAYS THE SAME. (DETAILS TO BE DETERMINED.)  
 3. INSTALL WALE SUPPORTS AT SHEET PILES AND SHIM PACKING BETWEEN SHEET PILES AND WALES.

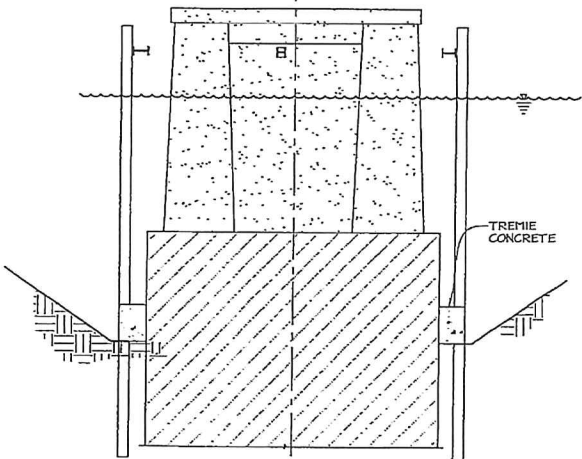

**STAGE 3:**  
 1. CONTINUE TO PROVIDE A HYDRAULIC CONNECTION THROUGH SHEET PILES SO THAT THE WATER LEVEL INSIDE AND OUTSIDE THE COFFERDAM IS ALWAYS THE SAME.  
 2. VERIFY THAT MUD LINE BETWEEN INSIDE FACE OF SHEETS AND OUTSIDE FACE OF EXISTING PIER I FOUNDATION IS STILL AT ELEVATION -34. EXCAVATE ADDITIONAL MATERIAL FROM WITHIN COFFERDAM IF NECESSARY TO ENSURE 5'-0" MINIMUM TREMIE CONCRETE THICKNESS.  
 3. PLACE TREMIE CONCRETE.

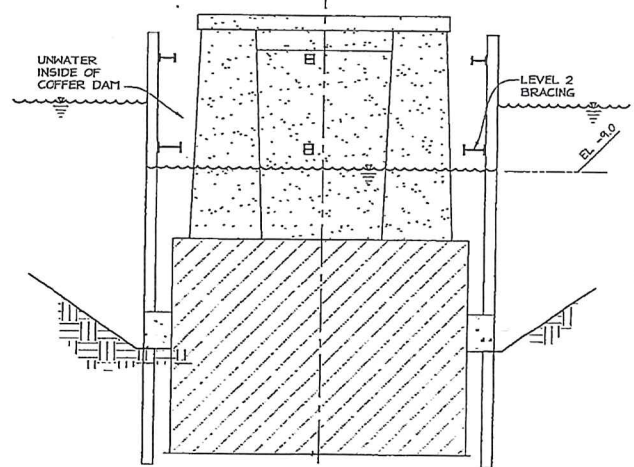

**STAGE 4:**  
 1. AFTER TREMIE CONCRETE HAS REACHED A STRENGTH OF AT LEAST 2500 PSI, SHUT OFF HYDRAULIC CONNECTION THROUGH SHEET PILES AND UNWATER INTERIOR OF COFFERDAM TO ELEVATION -9.  
 2. INSTALL LEVEL 2 BRACING.  
**NOTE:** ONLY PERFORM THIS CONSTRUCTION STAGE IN CALM WEATHER WHEN WAVE ACTION IS MINIMAL.

NO.		DATE	REVISIONS	BY	CK	OWNER	CLIENT	DESIGNED	CHECKED	DRAWN	DATE	CONTRACT	DATE	NO.	SCALE	SHEET	
						STATE OF CALIFORNIA DEPARTMENT OF TRANSPORTATION	SHIMMICK CONSTRUCTION	ESL	DJB	HC		CU 04253	MAY 7, 2012	10030	NO. 056713 CIVIL	1/8" = 1'-0"	CD-6
						DRAWING TITLE	PROJECT NAME	DATE	SCALE	SHEET							
						0 1' 2' 3'	10030_CD6.DWG										
						CONSTRUCTION SEQUENCE (1 OF 2)											
						6 OF 7											
						0											
						1/8" = 1'-0"											

82A



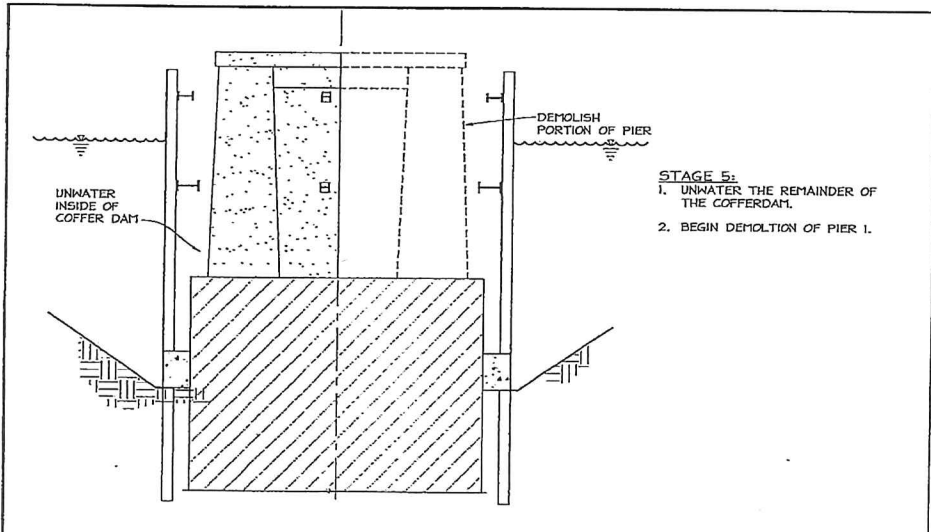

**STAGE 5:**  
 1. UNWATER THE REMAINDER OF THE COFFERDAM.  
 2. BEGIN DEMOLITION OF PIER 1.

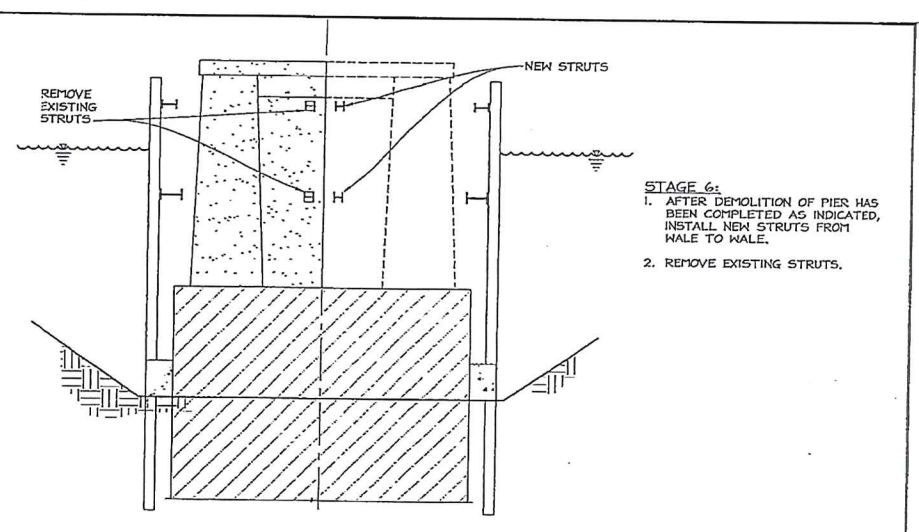

**STAGE 6:**  
 1. AFTER DEMOLITION OF PIER HAS BEEN COMPLETED AS INDICATED, INSTALL NEW STRUTS FROM PILE TO PILE.  
 2. REMOVE EXISTING STRUTS.

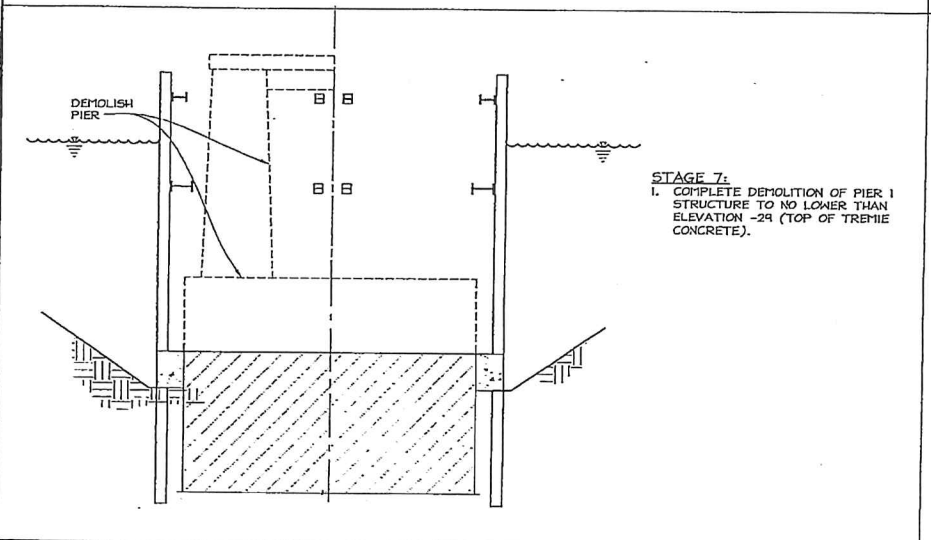

**STAGE 7:**  
 1. COMPLETE DEMOLITION OF PIER 1 STRUCTURE TO NO LOWER THAN ELEVATION -24 (TOP OF TREMIE CONCRETE).

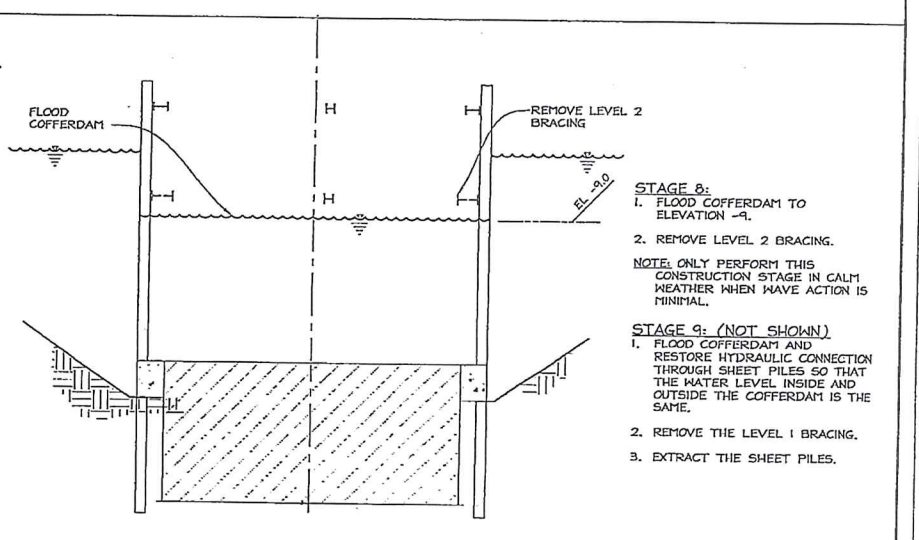

**STAGE 8:**  
 1. FLOOD COFFERDAM TO ELEVATION -9.  
 2. REMOVE LEVEL 2 BRACING.  
 NOTE: ONLY PERFORM THIS CONSTRUCTION STAGE IN CALM WEATHER WHEN WAVE ACTION IS MINIMAL.

**STAGE 9: (NOT SHOWN)**  
 1. FLOOD COFFERDAM AND RESTORE HYDRAULIC CONNECTION THROUGH SHEET PILES SO THAT THE WATER LEVEL INSIDE AND OUTSIDE THE COFFERDAM IS THE SAME.  
 2. REMOVE THE LEVEL 1 BRACING.  
 3. EXTRACT THE SHEET PILES.

NO.		DATE		REVISIONS		BY		CK		OWNER		CLIENT		DESIGNED		CHECKED		DRAWN		DATE		APPROVED		CONTRACT		DATE		JOB		SCALE		SHEET			
										STATE OF CALIFORNIA DEPARTMENT OF TRANSPORTATION		SHIMMICK CONSTRUCTION		BLCE BRLEY CONSULTING ENGINEERS, INC. 300 CALIFORNIA ELEVATION DRIVE, SUITE 200, BAKERSFIELD, CALIFORNIA 93311 (805) 833-8000 FAX (805) 833-8000 a Division of Briley Associates, Inc.		NO. 058213 OP. 152213 STATE OF CALIFORNIA REGISTERED PROFESSIONAL ENGINEER		DUMBARTON BRIDGE SEISMIC RETROFIT RAVENSWOOD PIER COFFERDAM AT PIER 1 CONSTRUCTION SEQUENCE (2 OF 2)		CU 04253		MAY 7, 2012		10030		1/8" = 1'-0"		CD-7		6 OF 7		0			

529

**STAFF REPORT TO THE CITY COUNCIL**

**DATE:** Special Meeting on December 15, 2020  
**TO:** Honorable Mayor and Members of the City Council  
**SUBMITTED BY:** Rosanna Bayon Moore, Assistant City Manager *RBM*  
**SUBJECT:** Bridging the Gap Virtual Roundtable Discussions

---

**RECOMMENDED ACTION**

It is recommended that the City Council provide staff direction.

**FISCAL IMPACT**

None.

**DISCUSSION**

Following a Request for Proposals (RFP) for Facilitation Services, the City of Antioch hired CNA, a nonprofit 501(c)(3), with professional experience assisting public agencies that seek to best support their communities with public safety services. Preparations are currently underway for CNA to convene a series of virtual roundtable discussions to better understand racial injustice and police-community relations. The information collected will be synthesized and presented as a set of recommendations for the City Council's consideration at a public meeting.

Three roundtable discussions are tentatively planned to launch in early 2021 and will focus on timely and relevant topics. The overall objectives of the dialogue are to obtain input from a broad cross section of the Antioch community, allow community members to listen and hear from each other and identify action steps based on community perspectives and preferences. The three roundtable discussion topics are: 1) Police Oversight, Accountability & Transparency, 2) Racial Disparities in Policing and 3) Police-Community Engagement.

At this time, CNA's recommended format is to provide a virtual setting for approximately 75 participants who reside or work in the City of Antioch. Participants will register in advance to join each dialogue and materials will be shared prior to the gathering. The City will lean heavily on CNA's professional depth and expertise to serve as the primary convener, presenter and recordkeeper of the roundtable discussions.

The total session length is 90 minutes and will open with a brief introduction by a subject matter expert that is publicly broadcast. Interactive discussion will follow in small group breakout sessions that occur off screen and will be moderated by CNA facilitators. The larger group will then re-convene in a public venue to receive a summary of the perspectives shared in each breakout group.

The proposed approach focuses on the participant experience and quality dialogue through interactive discussion. In CNA's professional opinion, rich information can be gathered in the proposed format and people who are not comfortable speaking in large groups can participate more comfortably.

Due to the provisions of the Brown Act, the Mayor and City Council Members roles are proposed as observation only. Select City staff will provide general event support and Antioch PD leadership will join as active listeners in plain clothes. A brief, online pre-event community survey is planned regarding meeting days and times, in addition to other meeting features. The survey and events will be broadly advertised.

City Council consensus is respectfully requested as it relates to CNA's recommended format.

**ATTACHMENTS**

None.



**STAFF REPORT TO THE CITY COUNCIL**

**DATE:** Special Meeting on December 15, 2020

**TO:** Honorable Mayor and Members of the City Council

**SUBMITTED BY:** Rosanna Bayon Moore, Assistant City Manager *RBM*

**APPROVED BY:** Ron Bernal, City Manager

**SUBJECT:** Reconsideration of the City's Acceptance of U.S. Department of Justice COPS Hiring Program Grant for School Resource Officers

---

**RECOMMENDED ACTION**

It is recommended that the City Council consider whether to adopt the resolution attached hereto as Attachment A rescinding Resolution 2020/121, which accepted grant funding in the amount of \$750,000 from the U.S. Department of Justice COPS Hiring Program to fund six (6) additional police officer positions to serve as School Resource Officers (SROs), and authorizing the City Manager or designee to amend the budget to reflect the cost savings as appropriate.

**FISCAL IMPACT**

In year one, the net annual SRO expense to the City is estimated at \$125,667 per police officer for a total of \$754,002 for 6 positions. The City and Antioch Unified School District ("AUSD") are cost sharing on a 50/50 basis. Annual step and benefit increases apply in years two and three. Total net cost to the City is estimated in excess of \$2M.

At the conclusion of the three-year award of funds, the City is required to retain the 6 positions for a minimum duration of one year and is responsible for 100% of the associated expense.

A rescission action will increase the General Fund fund balance in Fiscal Year 2020/21 for year one implementation. Future fiscal year budget projections will be amended to reflect cancelled SRO programming.

**DISCUSSION**

On July 28, 2020, the City Council approved Resolution No. 2020/121 to Accept Grant Funding in the Amount of \$750,000 from the U.S. Department of Justice COPS Hiring Program to Fund Six (6) Additional Police Officer Positions to Serve as School Resource Officers. The Chief of Police and AUSD Superintendent subsequently executed a Memorandum of Understanding (MOU).

Due to pandemic conditions, funded grant activities and personnel assignments have been delayed. The City has incurred no costs to date and, therefore, no draw down of grant funds has occurred.

### **POTENTIAL ALTERNATIVES**

Options include the following:

1. The City Council can adopt a resolution rescinding its acceptance of the U.S. Department of Justice COPS grant as reflected in the resolution attached hereto as Attachment A.
2. The City Council can reduce the number of SROs.
3. The City Council can opt to take no action.

### **ATTACHMENTS**

- A. Resolution rescinding Resolution No. 2020/121

Exhibit 1: Resolution No. 2020/121

**RESOLUTION NO. 2020/\*\***

**RESOLUTION OF THE CITY COUNCIL OF THE CITY OF ANTIOCH  
RESCINDING RESOLUTION NO. 2020/121, WHICH ACCEPTED GRANT FUNDING  
IN THE AMOUNT OF \$750,000 FROM THE U.S. DEPARTMENT OF JUSTICE COPS  
HIRING PROGRAM TO FUND SIX (6) ADDITIONAL POLICE OFFICER POSITIONS  
TO SERVE AS SCHOOL RESOURCE OFFICERS AND AUTHORIZING THE  
FINANCE DIRECTOR TO AMEND THE FISCAL YEAR 2020/21 AS APPROPRIATE**

**WHEREAS**, on July 28, 2020, the City Council adopted Resolution No. 2020/121 to accept \$750,000 of grant funding from the U.S. Department of Justice COPS Hiring Program (the "COPS Grant") to fund six (6) additional Police Officer positions to serve as school resource officers;

**WHEREAS**, the COPS Grant program requires that the City pay for the cost of salary and other benefits for the police officers to the extent not covered by the COPS Grant;

**WHEREAS**, a memorandum of understanding has been signed by the City's Chief of Police and the Antioch Unified School District ("AUSD") Superintendent of Schools concerning school resource officers;

**WHEREAS**, pursuant to a required Memorandum of Understanding ("MOU"), up to 50% of the base salary and benefits not covered by the COPS Grant for up to six (6) school resource officers are mitigated by payments from AUSD;

**WHEREAS**, the COPS Grant obligates the City to retain all sworn officer positions obtained under the Grant for at least one (1) year after the expiration of the three-year grant term;

**WHEREAS**, Resolution No. 2020/172 was adopted on November 24, 2020, amending the Fiscal Year 2020/21 budget to include funding with corresponding reimbursement from AUSD and the COPS Grant;

**WHEREAS**, the additional net cost to the City once all six (6) positions are filled is estimated in excess of 2 million dollars over the four-year period of the COPS Grant and retention period; and

**WHEREAS**, the City Manager or designee is authorized to make associated Fiscal Year 2020/21 budget adjustments to reflect reduced personnel expenditures, in addition to reduced reimbursement revenues from AUSD and the COPS Grant program for expenses incurred.

**NOW, THEREFORE, BE IT RESOLVED** that the City Council of the City of Antioch hereby:

1. Rescinds its adoption of Resolution No. 2020/121, a resolution of the City Council of the City of Antioch to accept grant funding in the amount of \$750,000 from the



**RESOLUTION NO. 2020/\*\***

December 15, 2020

Page 2

U.S. Department of Justice COPS Hiring Program to fund six (6) additional police officer positions to serve as school resource officers, and determines that the City shall not accept the U.S. Department of Justice COPS Hiring Program grant funding in the amount of \$750,000;

2. Terminates the MOU entered into between the AUSD and the City of Antioch; and
3. Authorizes the City Manager or designee to amend the Fiscal Year 2020/21 budget as appropriate.

**BE IT FURTHER RESOLVED** that the City Manager, or designee, is authorized to take any actions and execute any documents or agreements necessary to carry out the purposes of this resolution, subject to review and approval of, for or by the City Attorney.

\* \* \* \* \*

**I HEREBY CERTIFY** that the foregoing resolution was passed and adopted by the City Council of the City of Antioch at a special meeting thereof held on the 15th day of December 2020, by the following vote:

**AYES:**

**NOES:**

**ABSTAIN:**

**ABSENT:**

---

**ELIZABETH HOUSEHOLDER  
CITY CLERK OF THE CITY OF ANTIOCH**

**RESOLUTION NO. 2020/121**

**RESOLUTION OF THE CITY COUNCIL OF THE CITY OF ANTIOCH  
TO ACCEPT GRANT FUNDING IN THE AMOUNT OF \$750,000 FROM THE US  
DEPARTMENT OF JUSTICE COPS HIRING PROGRAM TO FUND SIX (6)  
ADDITIONAL POLICE OFFICER POSITIONS TO SERVE AS SCHOOL RESOURCE  
OFFICERS**

**WHEREAS**, this year the US Department of Justice awarded nearly \$400 million in grant funding through their Office of Community Oriented Policing Services ("COPS") Hiring Program to add additional sworn law enforcement officers to agencies across the nation;

**WHEREAS**, the COPS Hiring Program is a competitive grant program that provides funding directly to law enforcement agencies that have primary law enforcement authority to create and preserve jobs and to increase their community policing capacity and crime prevention efforts;

**WHEREAS**, the Antioch Police Department applied for funding through this program to hire six police officers and was awarded \$750,000 over the three-year grant period to pay a portion of the salary and benefit package for six police officers; and

**WHEREAS**, these six new police officer positions would be assigned and dedicated as school resource officers at the two primary high schools and all four middle schools in Antioch.

**NOW, THEREFORE, BE IT RESOLVED** that the City Council of the City of Antioch hereby approves the US Department of Justice COPS Hiring Program grant funding in the amount of \$750,000 to fund six additional police officer positions to serve as school resource officers, contingent upon approval of a 50 percent cost sharing agreement by the Antioch Unified School District Board of Trustees before August 9, 2020.

**BE IT FURTHER RESOLVED** that the City Manager, or his designee, is authorized to take any actions and execute any documents or agreements necessary for receipt of the grant funds subject to review and approval of form by the City Attorney.

\* \* \* \* \*

**I HEREBY CERTIFY** that the foregoing resolution was passed and adopted by the City Council of the City of Antioch at a regular meeting thereof, held on the 28th day of July 2020, by the following vote:

**AYES:** Council Members Motts, Ogorchock and Mayor Wright

**NOES:** Council Members Wilson and Thorpe

**ABSTAIN:** None

**ABSENT:** None



**ARNE SIMONSEN, MMC  
CITY CLERK OF THE CITY OF ANTIOCH**

CITY OF  
**ANTIOCH**  
CALIFORNIA

**STAFF REPORT TO THE CITY COUNCIL**

**DATE:** Special Meeting of December 15, 2020

**TO:** Honorable Mayor and Members of the City Council

**SUBMITTED BY:** Ron Bernal, City Manager 

**SUBJECT:** City Council Appointments to Council Committee Assignments and Ad Hoc Committees

---

**RECOMMENDED ACTION**

It is recommended that the City Council review and discuss City Council Committee Assignments and Ad Hoc Committees. Mayor Thorpe will be making new appointments for City Council approval by majority vote to be acted upon as follows:

- 1) Motion to approve all appointments for Mayor Thorpe,
- 2) Motion to approve all appointments for Mayor Pro Tem (Council Member District 4) – Wilson,
- 3) Motion to approve all appointments for Council Member District 1 – Torres-Walker,
- 4) Motion to approve all appointments for Council Member District 2 – Barbanica; and
- 5) Motion to approve all appointments for Council Member District 3 – Ogorchock.

**FISCAL IMPACT**

This recommended action has no direct fiscal impact. Providing staff support to Council Committee Assignments and Ad Hoc Committees impacts staff workloads.

**DISCUSSION**

At the December 8, 2020 City Council meeting, Mayor Thorpe requested appointments to the City/School Committee and the Cannabis Committee along with any Ad Hoc Committees to be brought back to City Council.

**ATTACHMENTS**

A. Council Committee Assignments and Ad Hoc Committees

**CITY OF ANTIOCH**

<b>Council Committee Assignments</b>		
City/School Committee	<i>TBD</i>	Standing Committee: As needed City Manager's Office to develop agenda and handle noticing
Cannabis Committee	Mayor Thorpe Mayor Pro Tem Wilson	Standing Committee: As needed City Attorney's Office to develop agenda and handle noticing
<b>Ad Hoc Committee Assignments</b>		
Transitional Housing Ad Hoc Committee	<del>Mayor Pro Tem Motts</del> <del>Council Member Thorpe</del>	Ad Hoc Committee- As needed City Manager's Office