

TABLE OF CONTENTS

I. GENERAL SUBMITTAL REQUIREMENTS FOR IMPROVEMENT PLANS3

A. Purpose 3

B. Required Items for Submittals 3

II. GENERAL REQUIREMENTS FOR IMPROVEMENT PLANS6

A. Plan Set Requirements 6

B. General Drafting 6

C. Typical Plan Set Layout 7

III. IMPROVEMENT PLAN - “PLAN” OR “LAYOUT” VIEW REQUIREMENTS9

A. Streets 9

B. Utilities - General 11

C. Sanitary Sewer Collection System 11

D. Water Distribution System 12

E. Storm Drain Collection System 13

F. Electroliers 13

G. Photometric Analysis 14

H. Joint Trench Plan 14

I. Signing and Striping Plan 15

J. Traffic Signal Plan 15

K. Vehicle Circulation Analysis Plan 17

L. Stormwater Control Plan and Report 18

IV. IMPROVEMENT PLAN - “PROFILE” VIEW REQUIREMENTS20

A. Streets 20

B. Utilities - General 21

C. Sanitary Sewer Collection System 21

D. Water Distribution System 22



DEVELOPMENT ENGINEERING DIVISION

- E. Storm Drain Collection System 22
- V. GRADING PLAN REQUIREMENTS23**
- A. References/Abbreviations 23
- B. Code Requirements 23
- C. Grading Plan Preparation..... 25
- VI. LANDSCAPING AND IRRIGATION PLAN REQUIREMENTS32**
- A. Design Requirements..... 32
- B. Landscape/Irrigation - Non-City Maintained 32
- C. Landscape/Irrigation - City Maintained 32
- D. Medians..... 34

I. GENERAL SUBMITTAL REQUIREMENTS FOR IMPROVEMENT PLANS

A. Purpose

The intent of this Checklist is to serve as a guide through the Improvement Plan review process and to establish minimums to be utilized in the design and drawings for public and private works. Design standards may be augmented by City Council action or by written approval of the Director of Public Works. Any items or situations not included within this Checklist shall be designed in accordance with accepted engineering practices, the City of Antioch Municipal Code, the City of Antioch Construction Details, and the latest editions of the California Department of Transportation Highway Design Manual (HDM), Caltrans Standard Plans and Specifications, California Manual on Uniform Traffic Control Devices (CA MUTCD) and as required by the Director of Public Works.

All submittal components shall be submitted together for the Subdivision Improvement Plan submittal to be considered complete. **Staff will not consider partial submittals for plan check.** At the discretion of the City Engineer, portions of the plan may be issued for permits but only after **submission of a complete submittal.**

B. Required Items for Submittals

1. Improvement Plans - Prepared by or under the direction of a Civil Engineer registered in the State of California, with every plan sheet signed, with seal or stamp and expiration date.
2. Conditions of Approval and Environmental Mitigation Measures Compliance Matrix to include:
 1. Written explanations outlining compliance for all conditions of approval.
 2. Written explanations outlining compliance for all environmental mitigation measure requirements.
3. Approved Vested Tentative Map – Improvement plans layout shall be in substantial conformance with approved Tentative Map.
4. Geotechnical report, letters or memo to include:
 1. Pavement sections recommendations.
 2. Foundation soils analysis and recommendations.
 3. Maximum slope recommendations.
 4. Slide repair and soils liquefaction mitigations identified.
 5. Retaining wall design factors identified.
 6. Identification of fault lines and Special earthquake zones.
 7. Identification and removal of all contaminated soils from the project.
 8. Any specific mitigation measures required.
5. Hydrology and Hydraulic Study (with hydrology maps) to include:
 1. Hydrology and hydraulic calculations, maps and reports per Contra Costa County Flood

DEVELOPMENT ENGINEERING DIVISION

- Control District requirements and City requirements.
2. Storm drain hydrology/ hydraulic calculations of the project drainage area.
 3. Impacts of the increased drainage flows on existing City storm drain system.
 4. Storm drainage site retention calculations and mitigations of impacts of increased storm drainage flows to downstream pipe and streams.
 5. Computation of areas of site that are self-treatment, impervious pavements and building roofs, site bioretention and pervious pavement areas.
 6. Determination of onsite water quality improvements and erosion control measures.
 7. Flood control map revision, and FEMA floodway mapping revisions.
6. Sanitary Sewer Hydraulic Study to include:
 1. Capacity study requirements per Central Contra Costa Sanitary Sewer District.
 2. Estimated sewer flows generated by the project.
 3. Analysis of impacts of new sewer of flows to downstream sewer system.
 4. Projected peak sewer capacity flows.
 7. Water System Study to include:
 1. Determine maximum day water system flows of proposed subdivision domestic water with fire hydrant flows analysis with existing city system.
 2. Prepare Fire flow calculations and fire hydrant system analysis.
 8. Engineer's Quantity and Cost Estimate to include:
 1. Onsite improvements including landscaping / irrigation.
 2. Offsite improvements including landscaping / irrigation.
 3. Construction phasing of improvements.
 4. Identify bonding requirements.
 5. Unit Costs comply with the most current City of Antioch Unit Cost List for Estimates.
 9. Grading Plans – See Section V for plan requirements.
 10. Joint Trench Plans – See Section III(H) for plan requirements.
 11. Landscape and Irrigation Plans – See Section VI for plan requirements.
 12. Waste Management Plan –
 1. <https://www.antiochca.gov/pscr/environmental-resources/business/c-and-d/>
 13. Stormwater Control Plan and Report – See Section III(L) for plan and report requirements.
 14. Structural Calculations
 15. Formation of new assessment district of proposed subdivision or annexation of subdivision to existing subdivision assessment districts in the vicinity of the project.



DEVELOPMENT ENGINEERING DIVISION

16. Any other applicable materials and information necessary for the plan check of the subject project improvement plans.

II. GENERAL REQUIREMENTS FOR IMPROVEMENT PLANS

A. Plan Set Requirements

1. Required Plan Sheets:
 1. Improvement Plan Sheets
 2. Grading Plan Sheets
 3. Landscape Plan Sheets
 4. Irrigation Plan Sheets
 5. Joint Trench and Streetlight Plan Sheets
 6. Signing/Striping
 7. Traffic Signal Plan Sheets
 8. Erosion Control Plan
 9. C.3 Design and Details
 10. Construction Details

B. General Drafting

1. Printed in black ink
2. 24" x 36" paper
3. 1" margin on all sides with 1/16" border
4. North arrow
5. Preferred graphic scales; 20 or 40 scale (horizontally); 4 or 8 scale (vertically). Other scales may be utilized upon City Engineer approval. Exaggerated scales for profiles or sections may not be utilized.
6. 1/10" lettering (min.)
7. Each sheet wet-signed, with seal/stamp of design engineer. Electronic signatures shall meet the requirements of GOV Code Section 16.5, CCR Section 22000, Title 2, Division 7, Chapter 10.
8. Title (cover) sheet
 1. City Signature Block:

REVIEWED FOR COMPLIANCE WITH TITLE 9 CHAPTER 4 OF THE ANTIOCH MUNICIPAL CODE.

ACCEPTED BY: _____ DATE: _____

DIRECTOR OF PUBLIC WORKS / CITY ENGINEER

2. Geotechnical Engineer Signature Block and statement.
9. Each sheet with standard title block along right side (preferred), with tract no., subdivision name, type of plan, sheet numbering, design firm, signature square, revision block).

C. Typical Plan Set Layout

1. Cover Sheet
 1. Vicinity Map with prominent streets, natural features and "Site" labeled.
 2. Sheet Index Map with type of plan sheet and sheet no.
 3. Benchmark.
 4. Basis of Bearings.
 5. Name and contact information for: Owner, developer, all design engineers and soils engineer.
 6. City Required Notes for Improvement Plans: general, construction, water, sanitary sewer, and storm drain. A separate sheet may be utilized for City and Project Notes.
 7. City Standard Construction Details listed - Any alteration of City Standard Details shall not be permitted without approval of the City Engineer.
 8. Legend (symbols)
 9. Utility representative chart including emergency contact information.
 10. Abbreviations
 11. Pavement Section Chart, including Traffic Index (TI), R-value, thickness (inch).
 - a. Min. AC pavement thickness per City Standard Construction Detail ST-26.
 - b. Traffic Index per City Standard Construction Detail ST-26.
2. General Sheets
 1. Typical Street Cross Section(s) showing: street name, right-of-way (ROW) width, face-of-curb (FOC) to face-of-curb width, sidewalk (SW) width, under-curb drain, 2% min. cross slopes, streetlights and any public easements.
 2. Utility Systems Map (100 scale) showing: right-of-way (ROW), property lines (PL's), lot #'s, electroliers, sanitary sewer (SS) line sizes, SS manholes (SSMH), water line (WL) sizes, fire hydrants (FH), blow-offs (BO), air release valves (ARV), storm drain (SD) line sizes, SD manholes (SDMH), and SD catch basins (SDCB).
 3. Typical Lot Service Detail showing: sanitary sewer & water laterals, boxes, driveway, drainage, setbacks
 4. Special or Non-Standard Details -
 - i. Details shall be in grid format and drawn to scale, details that cross multiple grids shall take all of the adjoining grid boxes. Grid box size must be the same for all plans in the set and not be different for each discipline.
 5. Water Systems Map (300 scale) (optional)
 6. Subdivision Map (600 scale) (optional)
 7. Schedules for Storm Drain and Sanitary Sewer (table of structure sizes, quantities)

3. Plan/Profile Sheets
 1. Plan View
 2. Profile View
 3. Key Map
 4. Storm Drain Details
 5. Curve Data chart
 6. Unwinds (e.g., knuckle, cul-de-sac bulb)

4. Profile View Only Sheets
 1. Curb Return Profiles
 2. Storm Drain Crossing Profiles
 3. Bio-Retention Facility Details (Plan & Profile)

5. Grading Sheets
 1. Grading Plan (Rough)
 2. Grading Cross Sections
 3. Retaining Wall Layout/Sections/Details (These may be included in a separate structural plan section)
 4. Erosion Control

6. Landscape and Irrigation Sheets
 1. Landscape Layout
 2. Fine Grading
 3. Planting Plan
 4. Landscape Details/Planting Details
 5. Irrigation Plan
 6. Irrigation Details

7. Joint Trench and Street Lighting Sheets
 1. Cover Sheet with PG&E Signature block
 2. Joint Trench Sections and Notes
 3. Joint Trench Layout with Street Lights
 4. Street Light Details
 5. Street Light Photometric Grid Sheet

8. Signing and Striping
 1. Signing & Striping Plan
 2. Sign and Striping Details
 3. Traffic Signal Plan
 4. Traffic Signal Wiring and Phasing
 5. Traffic Signal Details

III. IMPROVEMENT PLAN - "PLAN" OR "LAYOUT" VIEW REQUIREMENTS

A. Streets

1. Street names and lot numbers.
2. Adjoining sheets accurately referenced.
3. All existing streets, utilities and structures within 100' of tract boundary to be shown. Existing features to be shown screened or thin dashed lines.
4. Transition to existing grade shall be adequately shown and detailed. Transition shall be designed to adequately handle runoff and not create adverse grading or drainage conditions.
5. Street curb-to-curb and right-of-way widths shall be shown at least once on each sheet. Widths shall conform to City standards, tentative map (TM) and conditions of approval (COA's).
6. Streets to be symmetrical about the centerline (CL) unless otherwise directed by the City Engineer. Right and left face-of-curb (FOC) to be equal distance from the centerline.
7. Monument line (ML) shall be offset from centerline by 6'.
8. Distance of water line to centerline and face-of-curb to centerline shall be dimensioned. Sidewalk width shall also be shown.
9. Storm drain pipe centerline shall be located 0.67' from face-of-curb towards the street.
10. Curve Data Chart shall indicate delta, radius, length of all curves (e.g., centerline, sanitary sewer, storm drain, face-of-curb, water line).
11. Curb return profiles shall be shown on a separate sheet.
12. Minimum centerline radius for all streets shall conform to City of Antioch Municipal Code (AMC) §9-4.612 and the approved TM. If these are not consistent, then the design shall conform to whichever is more conservative.
13. Streets entering on opposite sides shall match centerlines and conform to AMC §9-4.607. Centerlines of streets entering a major street shall be offset a minimum of 800'. Centerlines of streets entering collector or local streets shall be offset a minimum of 200'.
14. Street centerline radii shall conform to the final map.
15. Streets shall intersect at right angles.
16. No curves (end-curve (EC) or begin curve (BC)) within 50' of intersections.
17. There shall be a minimum of 20' tangent (measured from the curb return) at all intersections or 50' from the centerline, whichever is longer.
18. Site obstructions at intersections and driveways shall comply with AMC §9-5.1101. Clear vision zones shall be shown at every intersection.
19. Horizontal and vertical curves must be designed to provide a line-of-sight based on minimum stopping sight distance and design mph, in conformance with AMC §9-4.611.
20. Through-the-curb drains shall comply with the City of Brentwood ST-27. A 2-inch diameter pipe to be used for rolled curbs and a 3-inch diameter pipe to be used for vertical curbs. Bubble-Up drains shall not be permitted.

DEVELOPMENT ENGINEERING DIVISION

21. Valley gutters (ST-08) shall not be allowed across major or collector roads. Valley gutters are not allowed at cul-de-sacs (CDS) and at local streets without prior written approval by the City Engineer.
22. Min. 2% cross-slopes on all new streets.
23. Curb returns shall have a min. R=30' (measured at face-of-curb).
24. Minimum slope around curb return is 0.50% in conformance with AMC §9-4.611(c)&(d).
25. Station and Top-of-Curb elevation (pavement elevation, rim, etc.) shall be shown at lot lines, street intersections, curb returns, begin curve, end curve, manhole, catch basin, fire hydrant, blow off valve, air-release valve, electroliers, and left & right medians as applicable.
26. Maximum and minimum driveway widths, refer to City Standard ST-02.
27. Centerline and flares (approach) of driveways shall be shown and labeled. Indicate station at centerline of driveway. Call out driveway widths.
28. Outside edge of driveway flares shall be a minimum of 5' from fire hydrant in conformance with AMC §9-4.630.
29. Driveways shall be a minimum of 5' from curb returns and located at the far side of the lot from the curb return.
30. Monuments shall be shown and located 6' offset from centerline (opposite water line).
31. Top-of-Curb elevation shall be minimum of 10' above sea level.
32. One 20' parking space for each lot in cul-de-sac required unless otherwise specified by conditions of approval.
33. Road centerline shall be stationed at 100' intervals, with stationing numbered from left to right.
34. Barricades are to be shown and labeled at all temporary dead-end streets and sidewalks per the MUTCD.
35. Accessible ramps shall be shown at all curb returns and shall conform with ST-12.
36. **Table of Min./Max. Street Design Values** per AMC §9-4.611 & §9-4.612.

Street Type	Local	Collector	Major Arterial
Min. CL Horizontal Curve Radius (AMC §9-4.612) [ft.]	100	200	650
Max. Grades [%]	15	10	6
Min. Vertical Curves [ft.]	50	100	200
Crest Vertical Curve Max. Rate of Change [%] per 100'	10	4	1.2
Street CL offsets [ft.]	200	200	800
Min. Stopping/Sight Distances [ft.]	100/180	200/240	350/400

B. Utilities - General

1. Plan and profile station/top-of-curb elevations shall agree.
2. All existing utilities (storm drain, sanitary sewer, water lines, joint trench, top-of-curb elevations, etc.) within 100' of planned street shall be shown as screened or fine dashed lines.
3. All new utilities shall be placed underground (exception: PG&E pedestals). Pad mounted hardware (PMH) that cannot be placed underground shall be screened with landscaping.
4. Minimum 10' wide easements required for all water lines, sewer lines and storm drain lines not located within street right-of-way. For larger pipes, minimum easement width = pipe diameter + 4' clear (both sides of pipe).
5. Easements shall not be divided/split by property lines. Entire easement shall be on one lot/parcel, unless approved by City Engineer.

C. Sanitary Sewer Collection System

1. Sanitary sewer (SS) lines shall be located along centerline of street.
2. All sanitary sewer horizontal curves shall be labeled.
3. All proposed sanitary sewer manholes (SSMH) shall be shown with structure #, stationing information, rim and invert elevations.
4. Sanitary sewer system design shall be consistent with Central Contra Costa Sanitation District (CCCSD) plans and specifications, except as noted herein.
5. Minimum sanitary sewer pipe diameter is 8". With prior approval from City Engineer, 6" diameter pipe may be used on cul-de-sacs where flow velocity is an issue.
6. Joint deflections cannot exceed 80% of manufacturer's min. recommendations.
7. Manholes shall be placed at all street intersections and ends of lines, wherever direction of flow (horizontal and vertical) or pipe size changes.
8. Sanitary sewer stubs shall extend a 10' beyond phased construction line.
9. Maximum spacing between sanitary sewer manholes shall be 500'.
10. Sanitary sewer manholes shall have eccentric cones.
11. Any proposed sanitary sewer crossings comply with California Code of Regulations, Title 22, Division 4, Chapter 16, Section 64572.
12. Sanitary sewer laterals entering from main from opposite sides of pipe shall be separated a minimum of 2'.
13. Sanitary sewer laterals shall maintain 5' of clearance from water laterals and driveways. Deviations to be approved by City Engineer.
14. Sanitary sewer main not located in road right-of-way shall be centered in minimum 10' wide sanitary sewer easement and minimum of 5' from all property lines.
15. Sanitary sewer & water laterals shall be shown for each lot and shall match the lot detail.

D. Water Distribution System

1. Water (W) lines shall be labeled and located 10' offset from centerline and on opposite side of street from monument line (ML).
2. Type, diameter, horizontal curves and length of pipe shall be labeled in plan and profile views.
3. C900 pipe shall be utilized for water lines with a diameter 18" or less. Ductile iron pipe (DIP) shall be used for water lines with a diameter greater than 18".
4. Cathodic Protection (CP) shall be designed and installed per City standards CP-01 through CP-09. Cathodic Protection stations shall be located a minimum of 500' apart.
5. Water pipe sizes shall be consistent with the City of Antioch's Water Systems Master Plan.
6. Water valves shall be shown in plan view. Place a min. 4 valves at 4-way intersections, min. 3 valves at tee intersections, and 1 valve at knuckle / cul-de-sac (CDS).
7. Inline water valves shall be placed no farther than 500' apart.
8. Provide gate valves to adequately isolate the water system segments. Valves shall be provided at each and every leg of the distribution system.
9. No more than two (2) fire hydrants per check valve.
10. Water valves for pipe diameter less than 14" shall be gate valves. Water valves for pipe diameter 14" and greater shall be butterfly valves.
11. Inline water line reducers shall not be permitted. Each leg of cross and tee shall match size of water line. Gate valve diameters shall match the diameter of the water line.
12. Air release valves (ARV) shall be installed at all high points within the water line.
13. Blow-off (BO) valves shall be installed at low points and temporary end of lines. Fire hydrants shall be installed at end of water line within cul-de-sacs.
14. If water line ends with at high point within a cul-de-sac, an air release valve and fire hydrant shall be installed within cul-de-sac.
15. A 1" tap and corp stop shall be provided for public landscape irrigation planting areas unless otherwise required by the City Engineer.
16. A reduced pressure backflow preventer (W-11) shall be provided in public landscape irrigation planting areas.
17. Fire hydrants shall be located on the same side of the street as the water line and 1.5' behind the sidewalk (SW) or face-of-curb and shall be installed in conformance with W-02a and W-02b.
18. Fire hydrants shall be located at intersections. Spacing between fire hydrants shall be a minimum of 300' and a maximum of 450'.
19. Fire hydrants shall be located 5' clear of driveway flares (measured from top of flare).
20. Fire hydrants shall not be located within the back-out zones of cul-de-sac's modified with center parking spaces.
21. Fire hydrants shall be installed a minimum of 5' away from sanitary sewer laterals.
22. Water meter lids to be touch read – N16R – Marked "Water" w/ Badger Orion Probe Hole.

E. Storm Drain Collection System

1. Storm Drain (SD) lines shall be located 0.67' offset from face-of-curb (for pipes < 27" in diameter).
2. Storm drain pipes, manholes and horizontal curves shall be called out in plan view.
3. Minimum storm drain pipe size/type is 18" Class III RCP (reinforced concrete pipe) within City right-of-way. Cast-in-place pipe (CIPP) shall only be allowed with written approval by City Engineer.
4. Storm drain pipe sizes shall match the hydrologic/hydraulic analysis/calculation report.
5. Catch basins (CB) shall comply with City Standard Construction Details SD-04 or SD-05.
6. Where storm drain pipe follows curve of street and pipe radius is less than 80% manufacturer's min. recommendations, 4' length pipes may be used and noted on plans.
7. At curb returns, catch basins shall be located on uphill side of curb returns at intersections.
8. Catch basins shall be located at all low points.
9. A catch basin or manhole shall be placed at all intersections and changes in pipe direction (horizontal or vertical), size, and grade.
10. Max. spacing between structures shall not exceed 400' on tangents.
11. Storm drain manholes shall have eccentric cones.
12. Max 500' runoff/gutter flow in street before an inlet is required unless a specific gutter flow velocity and spread analysis is prepared and submitted for each segment.
13. Catch basins shall be placed at extension of lot lines and at end of curb returns.
14. Centerline of catch basins shall be 2' from curb return.
15. Outside edge of catch basin shall be a minimum of 5' clear from driveway flares.
16. Storm drain lines not located within road shall be centered in 10' wide storm drainage easement and shall be 5' from any property line.
17. Existing facilities should agree with reference plans.
18. Storm drain laterals / crossings shall cross streets perpendicularly (i.e., at 90°).
19. All structures shall be labeled with structure #, station and top-of-curb elevation.
20. Field inlets (FI) shall be labeled with top of grate (TOG) elevation and side opening elevation (SO - flowline at side opening).
21. HGL10 shall be lower than or equal to 1.5' below top-of-curb elevation.
22. HGL100 shall be lower than or equal to 1' below front pad elevation.
23. All inlets shall be labeled "No Dumping—Drains to River" with City decals.
24. Storm drain line shall extend a minimum of 10' beyond phased construction line.
25. Overland release path and release elevations shall be noted on plans. Runoff shall be released before the elevation at the low point (with plugged catch basins) exceeds 0.5' above the top-of-curb and lot flooding occurs.

F. Electroliers

1. Streetlights shall conform to City Standard Construction Detail ST-18.
2. At intersections, both ends of opposing medians shall have electroliers placed in medians, equal distance from intersecting street centerlines.

3. Electroliers shall be placed at extension of lot lines or on side yard (long side) of corner lots.
4. Electroliers are to be placed at all intersections and at the far-right return (i.e., downside of traffic at intersection) of major or through street.
5. Electroliers are not to be located within the back-out zone of cul-de-sacs modified with center parking spaces.
6. Streetlight poles shall have a 5.0' minimum clearance from catch basins and fire hydrants.
7. Proposed street trees shall not conflict with proposed Streetlights. In the case of a streetlight and street tree conflict, the streetlight location will have first priority.

G. Photometric Analysis

1. Streetlights shall comply with City Standard Construction Details Drawing No. ST-18.
2. Standard Scale shall be 1" = 20' or as approved by City Engineer.
3. Luminaire Schedule shall have details for the symbol, label, quantity, height, wattage, Manufacturer, catalog number, and description.
4. Photometric calculations shall have area description, symbol, average, maximum, minimum, minimum/average ratio, and minimum/maximum ratio.
5. Include existing luminaires in schedule and calculations.
6. Provide spillover spot calculation points.
7. Show each luminaire's canopy isolines.
8. Remove unnecessary topographic, utility, grading, pavement markings, or any information that will affect legibility of photometric analysis.

H. Joint Trench Plan

1. Joint trench centerline shall be centered 1' from back-of-walk for monolithic sidewalk or 1' from front of walk for detached sidewalk.
2. Joint trench lateral runs shall maintain 5' horizontal separation from sanitary sewer and water laterals.
3. Provide location and utility type for all proposed and existing utility provider improvements (PG&E, ATT, Cable TV, Internet and all other providers).
4. Minimum of 1' clearance required from joint trench & utility crossings as required by PG&E.
5. Minimum of 1' clearance required between the PG&E vaults and irrigation lines.
6. Utilities to be installed underground per Antioch Municipal Code Section 9-5.1101.
7. Plan sheets shall indicate the max height of all proposed above ground transformers measured from surrounding final grade to top of transformer.
8. Place pad mounted transformers on property lines, side yards and on City property. Avoid placement of pad mounted transformers within residential lot frontages.
9. Pad mounted transformers shall not impact clear vision zones for driveways and intersections as required by Antioch Municipal Code Section 9-5.1101.
10. Streetlight conduits shall be 2" per City Standard Construction Detail ST-18.
11. Streetlights to be shown on joint trench plans.

I. *Signing and Striping Plan*

1. Standard Scale shall be 1" = 40'; use 1" = 20' when additional detail is required.
2. Engineer's stamp, signature, expiration date.
3. No unnecessary topographic, utility, grading, or etc. information that will affect legibility of plan.
4. Existing signing and striping shall be depicted with thin, gray line types.
5. Proposed signing and striping shall be depicted with bold, black line types.
6. Proposed sign and striping installations compliant with the latest versions of the CA-MUTCD standards and Caltrans Standard Plans.
7. Proposed striping and pavement markings to be installed in thermoplastic, unless approved by the City Engineer.
8. Call out all new signing with reference to the naming convention of the latest edition of the California Manual on Uniform Traffic Control Devices (CA-MUTCD).
9. Call out sizes of proposed signs in legend and sizes of signs to remain in plan.
10. Call out all signs and striping to be removed, to remain, or to be relocated.
11. Call out all new pavement striping with reference to the detail numbers in the latest version of Caltrans Standard Plans.
12. Refer to Sheet A90A in the Caltrans Standard Plans for accessible parking design requirements.
13. Provide lane widths. For segments spanning multiple sheets, show lane widths on each sheet.
14. All striping dimension widths shall be measured at the center of striping detail.
15. Provide adequate taper and transition lengths and dimensions.
16. Show conformance to existing striping at project limits.
17. Install SW24-2(CA) and SW24-3(CA) sign combination with required "SLOW SCHOOL XING" pavement markings for all uncontrolled crosswalks within school areas.
18. Install W11-2 and W16-9P and W11-2 and W16-7P sign combinations for all uncontrolled crosswalks outside of school areas.
19. Refer to Antioch Construction Details Drawing No. ST-22a to ST-22d for Parking Stall Layout standards.

J. *Traffic Signal Plan*

1. Standard Scale shall be 1" = 20'.
2. Engineer's stamp, signature, expiration date.
3. Existing traffic signal infrastructure shall be depicted with thin, gray, dashed line types.
4. Proposed signal infrastructure shall be depicted with bold, black line types.
5. Design for a spare case on signal mast arms, whenever possible.
6. Include Battery Backup System (BBS) and batteries, if not already present.
7. Conductor Splicing -
 1. No splices are allowed in conductors for vehicle indications, pedestrian indications, pedestrian push buttons, detector lead-in cable, interconnect, emergency vehicle priority, or pre-emption.
8. Salvaged equipment -

DEVELOPMENT ENGINEERING DIVISION

1. Equipment to be removed and salvaged shall be delivered to the City of Antioch Corporation Yard. City staff must be notified a minimum of three (3) business days prior to delivery.

9. Internally Illuminated Street Same Signs shall be installed on pole or pole support arm, not on signal mast arm. See Detail below.

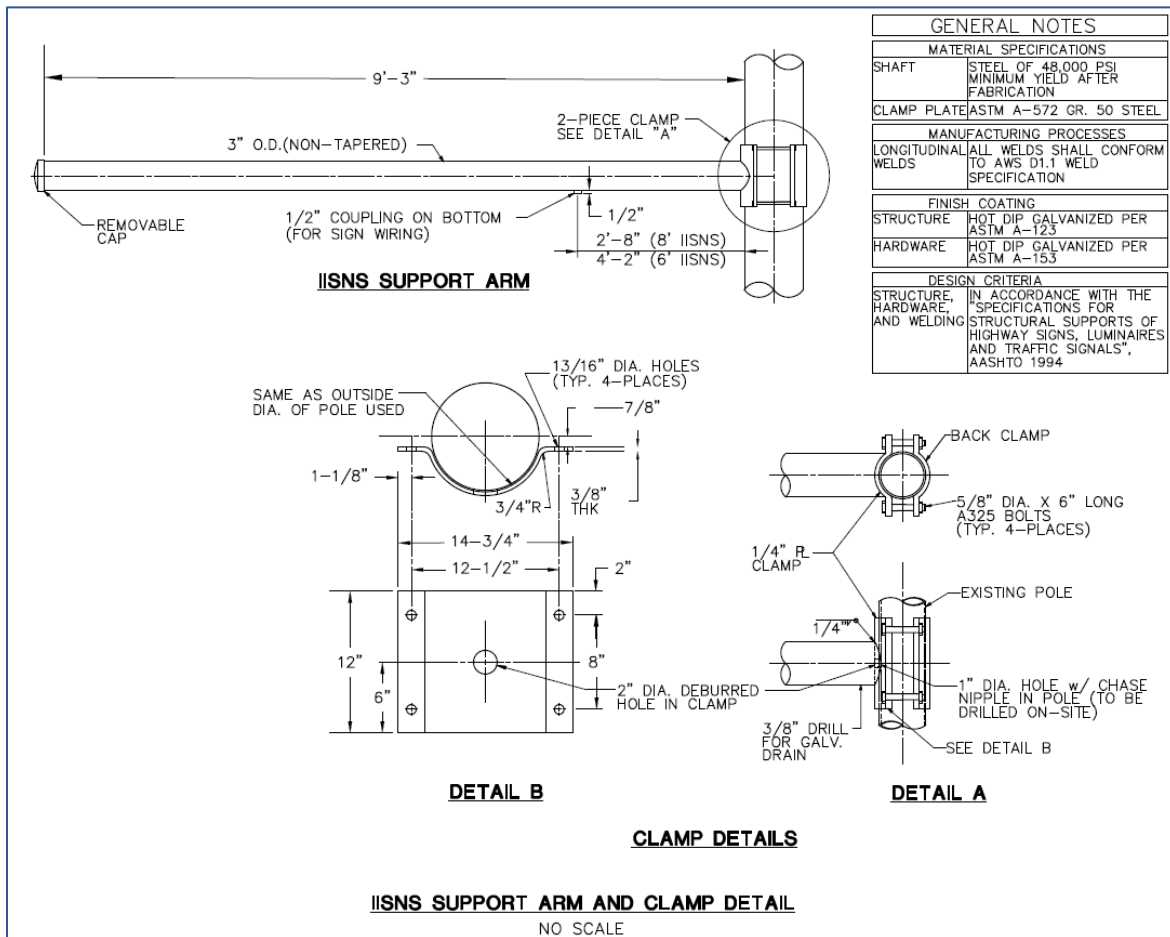

10. Poles shall have alphabetic labels.
 1. Existing poles shall be labeled with lower case letters and proposed poles shall be labeled with capital letters.
 2. Poles shall be labeled clockwise beginning at the top left corner of the plan.
11. Conduits -

1. Conduit runs shall have numerical labels and labeled in clockwise order.
2. New conduits shall be 4" in diameter.
3. Two (2) – 4" conduits shall be installed between home run pull box and controller cabinet.
12. Controller shall be McCain Flex Controller with Omni Software or approved equal.
 1. Cabinet shall be Model 332 Controller Cabinet.
13. Vehicle signal indications must be 12-inch, light-emitting diodes (LEDs).

14. Pull boxes -
 1. Shall be #6 for poles and for boxes with four (4) or more conduits.
 2. Home run box (box at controller cabinet) shall be #6(E).
 3. Otherwise, #5 boxes may be used.
15. Vehicle Detection Loops –
 1. First vehicle detector loop (closest to limit line) shall be Type D.
 2. All other vehicle detector loops shall be Type E.

K. Vehicle Circulation Analysis Plan

1. Standard Scale shall be 1" = 40'; use 1" = 20' when additional detail is required.
2. The Vehicle Tracking application (previously referred to as AutoTURN) in AutoCAD shall be used for analysis.
3. The Signing and Striping Plan shall be used for the base map.
4. AASHTO 2011 design vehicle WB-40 – Intermediate Semi-Trailer shall be used to analyze circulation within site, including ingress and egress, unless otherwise specified by the City Engineer.
5. In areas where vehicle size is a restriction, such as a drive-thru, an SUV similar to the North American 2009 Ford Escape 4WD SUV shall be used.
6. Show wheel path and vehicle swept maneuver path.
7. Include vehicle profile and undercarriage diagram and description.

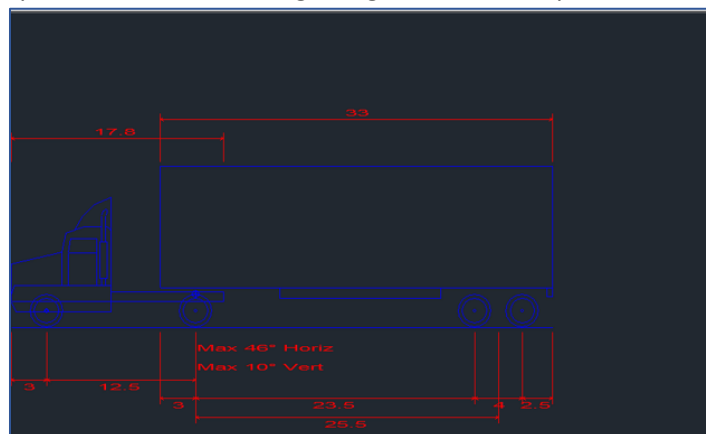

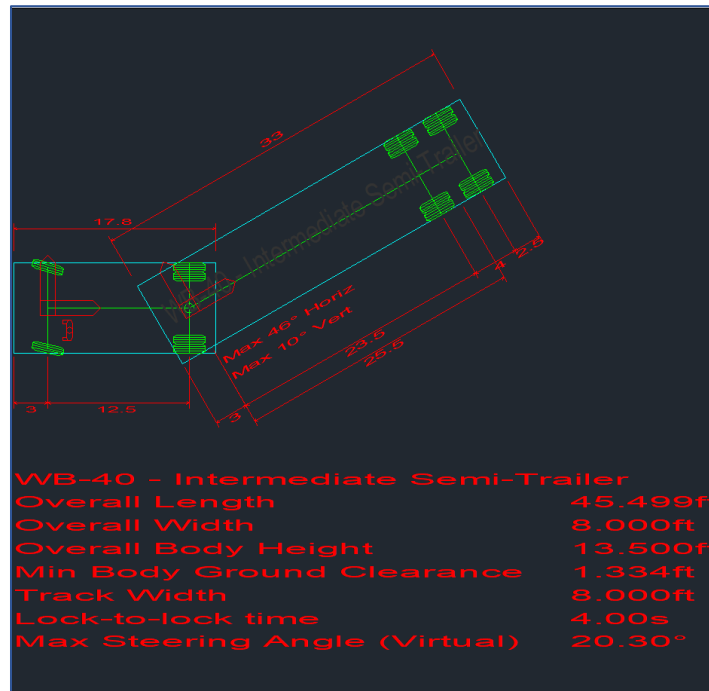

L. Stormwater Control Plan and Report

1. The following checklist is adapted from the Stormwater C.3 Guidebook which contains a detailed description and instructions for preparing a stormwater control plan. The Guidebook is available online at the following link or it may be purchased from the City of Antioch.
 1. https://www.cccleanwater.org/userfiles/kcfinder/files/2022_1223_HAI_StormwaterGuidebook_8th_Edition_FINAL_D2.pdf
2. Scaled (1" = 20', 40', 50' or 100') plans shall include:
 1. Existing natural hydrologic features (depressions, watercourses, relatively undisturbed areas) and significant natural resources.
 2. Soil types and depth to groundwater (if infiltration is proposed).
 3. Existing and proposed site drainage network and connections to drainage offsite.
 4. Proposed design features and surface treatments used to minimize imperviousness.
 5. Separate drainage areas, depending on complexity of drainage network.
 6. Existing condition of each drainage area, including pervious and impervious areas.
 7. For each drainage area, types of impervious area (roof, plaza/sidewalk, and streets/parking) and area of each.
 8. Proposed locations and approximate sizes of infiltration, treatment, or hydrograph modification BMPs.
 9. Pollutant source areas, including loading docks, food service areas, refuse areas, outdoor processes and storage, vehicle cleaning, repair or maintenance, fuel dispensing,

equipment washing, etc., and corresponding required source controls from Appendix D of Stormwater C.3 Guidebook.

3. Report accompanying the plans shall include:
 1. Narrative analysis or description of site features and conditions that constrain, or provide opportunities for, stormwater control.
 2. Narrative description of site design characteristics that protect natural resources.
 3. Narrative description and/or tabulation of site design characteristics, building features, and pavement selections that reduce imperviousness of the site.
 4. Tabulation of pervious and impervious area, showing self-retaining areas and areas tributary to each infiltration, treatment, or hydrograph modification BMP.
 5. Preliminary designs, including calculations, for each treatment or hydrograph modification management BMP. Elevations should show sufficient hydraulic head for each.
 6. A table of identified pollutant source areas and for each, the source control measure(s) used to reduce pollutants to the maximum extent practicable. See worksheet in Appendix D, Stormwater C.3 Guidebook.
 7. Identification of any conflicts with codes or requirements or other anticipated obstacles to implementing the Stormwater Control Plan.
 8. Construction and annual maintenance cost estimates for proposed BMP.
 9. General description of maintenance needs for treatment/hydrograph modification BMPs.
 10. Brief summary of other BMP methods not chosen for the project (including basic cost and C-3 efficiency estimates).
 11. Means by which BMP maintenance will be financed and implemented in perpetuity.
 12. Statement accepting responsibility for interim operation & maintenance of treatment BMPs.
 13. Construction Plan C.3 Checklist.
 14. Certification by a licensed civil engineer, architect, and landscape architect.

IV. IMPROVEMENT PLAN - “PROFILE” VIEW REQUIREMENTS

A. Streets

1. Street profiles shall include stationing and top-of-curb elevations at 100’ intervals.
2. Street profiles shall be labeled at centerline (CL). Centerline and top-of-curb elevations should be equal unless otherwise approved by the City Engineer.
3. Vertical scale shall be 1” = 4’ or 1” = 8’.
4. Profile view shall match Plan view and structures stationing shall “line up” underneath Plan view.
5. Existing and proposed grade at centerline shall be shown and labeled. Existing grades shall be shown as screened or fine dashed lines and extend 50’ beyond all conforms.
6. Transition to existing grade shall be adequately shown and detailed. Transition shall be designed to adequately handle runoff and not create adverse grading or drainage conditions.
7. Profile of streets shall continue through intersections. Where a through street appears along the profile of a secondary street, the profile of the secondary street is interrupted and the cross-slope of the through street is shown as a dashed line.
8. At the end of cul-de-sacs, the centerline after the inside cul-de-sac return and to the radial point shall be shown as a dashed line.
9. Minimum street profile grade is 0.75%.
10. All street slopes shall be labeled.
11. The grade of the pavement surface across an intersection shall not be more than 6% in conformance with AMC §9-4.611(C).
12. The gradient of each street entering an intersection shall not be more than 6% within a distance of 30’ from the near curb line of the crossing street in conformance with AMC §9-4.611(D).
13. Vertical curves for sags and crests shall be designed per Highway Design Manual and in no case less than as shown on Table of Min. & Max. Street Design Values per AMC §9-4.611 & §9-4.612.
14. Table of Min./Max. Street Design Values per AMC §9-4.611 & §9-4.612.

Street Type	Local	Collector	Major Arterial
Min. CL Horizontal Curve Radius (AMC §9-4.612) [ft.]	100	200	650
Max. Grades [%]	15	10	6
Min. Vertical Curves [ft.]	50	100	200
Crest Vertical Curve Max. Rate of Change [%] per 100’	10	4	1.2
Street CL offsets [ft.]	200	200	800
Min. Stopping/Sight Distances [ft.]	100/180	200/240	350/400

15. No grade breaks allowed. Changes of grade in the vertical alignment of the streets shall be made with parabolic vertical curves, in conformance with AMC §9-4.611(E).
16. Identify vertical curves by stationing and elevations for PIVC, BVC, EVC, HP and length.
17. Provide a min. 20' vertical curve for curb returns.
18. Vertical and Horizontal curves shall conform to Highway Design Manual minimum stopping distance. Where vertical curves occur concurrently with horizontal curves, length of curve shall be increased by 20%.
19. Gutter flow profiles shall be shown for ALL curb returns, cul-de-sacs and knuckles. Min. gutter slope is 0.75%.
20. Gutter flow for Q100 shall not extend more than 6' from face-of-curb.
21. Show centerline grade for all tangents.

B. Utilities - General

1. ***Please note, if not otherwise covered, the City of Antioch has adopted Central Contra Costa Sanitary District (Central San) standards.***
2. All existing pipes and structures shall be shown screened or with fine dashed lines, with flowlines and inverts labeled.
3. All proposed pipelines shall be shown as two parallel lines, with all proposed structures.
4. No steps (rungs) are allowed in manholes.

C. Sanitary Sewer Collection System

1. All proposed Sanitary Sewer (SS) lines shall be shown and labeled with pipe material, diameter, length, and slope information. All proposed sanitary sewer manholes (SSMH) shall be shown with structure #, stationing information, rim & invert elevations.
2. Whenever pipe direction changes by more than 30°, there shall be a 0.25' drop provided at the manhole. The invert in shall be 0.25' higher than the invert out.
3. Sanitary sewer pipe slope shall be designed to flow at a minimum velocity of 2 feet-per-second (fps).
4. Minimum cover over sanitary sewer lines along road centerline shall be 5'. Shallower depths allowed by Central San standards must be either pre-approved by City Engineer or allowed by letter of design exception.
5. Sanitary sewer laterals shall have a minimum of 3' cover and a maximum of 5' cover, measured from the bottom of curb and gutter concrete section to the top of lateral and in conformance with City Standard Construction Detail SS-05.
6. Sanitary sewer laterals shall have a minimum 2% slope and end with a sewer cleanout located within the City right-of-way, in conformance with City Standard Construction Detail SS-04.
7. Any proposed sanitary sewer crossings shall comply with California Code of Regulations, Title 22, Division 4, Chapter 16, Section 64572.
8. Sanitary sewer lateral cover table shall be provided on the project plans.
9. Sanitary sewer lines shall have 5-foot (5') min. vertical curve lengths and deflections at 80% of

manufacturer’s recommendations.

10. Avoid deep sewer lines due to excessive maintenance efforts. Sewers must not be deeper than 14’ from finished grade without prior coordination at the preliminary design phase and design exception letter documenting justification for the increased depth. Special design requirements, easement widths and setbacks may be required.

D. Water Distribution System

1. Water (W) lines shall be shown and labeled with pipe material, diameter, and length.
2. Water lines shall have a minimum of 3.5’ cover.
3. All water valves, air release valves (ARV) and blow-offs (BO) shall be shown and labeled.
4. Flowlines of water line and inverts of sanitary sewer or storm drain line shall be called out wherever pipes cross.
5. Any proposed water line utility crossings shall comply with California Code of Regulations, Title 22, Division 4, Chapter 16, Section 64572.
6. Blow-off valves shall be shown and labeled at all low points.
7. Air release valves shall be shown and labeled at all high points.

E. Storm Drain Collection System

1. Storm Drain (SD) lines shall be shown and labeled with pipes diameter, material, length, and slope.
2. Storm drain structures (manholes, catch basins, field inlets) shall be shown and labeled with structure #, rim and side opening flowlines, inverts, and HGL10 and HGL100 per hydrologic/hydraulic calculations.
3. All storm drain pipes shall be a min. 18” Class III RCP, unless otherwise approved by the City Engineer.
4. Storm drain manholes shall be located at all changes in pipe diameter and flow direction.
5. Match crowns/soffits in MH or CB whenever pipe diameter changes.
6. Whenever pipe direction changes by more than 30°, there shall be a 0.25’ drop provided at the manhole. The invert in shall be 0.25’ higher than the invert out.
7. Provide min. 3 foot (3’) of cover over SD lines.

8. Min. SD slopes (based on n=0.012, V=3 fps, pipe flowing ½ full):

Pipe Diameter [in.]	18	21	24	30	36	42
Pipe Slope [ft./ft.]	0.0026	0.0021	0.0017	0.0013	0.0010	0.0008

9. Manholes with an invert depth of 10’ or greater shall be a 60-inch diameter MH.
10. Depths greater than 30’ require special structural design and special inspections.

V. GRADING PLAN REQUIREMENTS

A. References/Abbreviations

- Antioch CA Code of Ordinances (ACO)
- 2019 California Building Code (CBC) Chapter 18 - Soils & Foundations
- 2019 California Residential Code (CRC)
- Business and Professions Code (BPC)

B. Code Requirements

1. A preliminary soils report is required where a tentative and final map is required pursuant to Government Code § 66426 (CBC 1803.1.1.1). Prior to submittal of final map, a preliminary soils report, prepared by a civil engineer registered by the state and based upon adequate test borings or excavations of every subdivision, as defined in Cal. Gov't Code § 66426, is required. The preliminary soils report may be waived if the City Engineer determines that no preliminary analysis is necessary due to known soil qualities of the subdivision. ACO § 9-4.513
2. A Geotechnical soils investigation report is required where the preliminary soils report indicates the presence of expansive soils or other soil problems which, if not corrected, would lead to structural defects. CBC 1803.1.1.2
 - a. A report of investigation and a statement by competent soils engineer as to the stability of areas in which slides have occurred, within or immediately adjoining the proposed subdivision or in which there is a slide hazard, shall be submitted with the tentative map, when required by the City Engineer. ACO § 9-4.307(B)
 - b. If the preliminary soils report indicates the presence of critically expansive soils or other soil problems which, if not corrected, would lead to structural defects, a soils investigation of each lot in the subdivision shall be prepared by a civil engineer who is registered by the state. The soil investigation shall recommend corrective action which is likely to prevent structural damage to each dwelling proposed to be constructed on the expansive soil. The soil investigation shall be filed with, and approved by, the City Engineer. ACO § 9-4.514, § 9-4.515
 - c. The soils investigation shall be conducted per CBC 1803.2-1803.5 and the written report shall contain the information specified in CBC 1803.6. This geotechnical report shall include, but need not be limited to, the following information:
 - i. A plot showing the location of the soil investigations.
 - ii. A complete record of the soil boring and penetration test logs and soil samples.
 - iii. A record of the soil profile.
 - iv. Elevation of the water table, if encountered.
 - v. Recommendations for foundation type and design criteria, including but not limited to bearing capacity of natural or compacted soil; provisions to mitigate

DEVELOPMENT ENGINEERING DIVISION

- the effects of expansive soils; mitigation of the effects of liquefaction, differential settlement, and varying soil strength; and the effects of adjacent loads.
- vi. Expected total and differential settlement.
 - vii. Deep foundation information in accordance with CBC 1803.5.5.
 - viii. Special design and construction provisions for foundations of structures founded on expansive soils, as necessary.
 - ix. Compacted fill material properties and testing in accordance with CBC 1803.5.8
 - x. Controlled low-strength material properties and testing in accordance with CBC 1803.5.9.
 - xi. [OSHPD 2] The report shall consider the effects of seismic hazard in accordance with CBC 1803.7.
3. A Geohazard report is required for all proposed construction per CBC 1803.7.
 4. The City Engineer shall specify the structural design for the streets. After the rough grading has been completed, the City Engineer shall have tests performed, at the subdivider's expense, to determine the final structural design of the roadbed. ACO § 9-4.609(B),(C)
 5. Earth slopes in cuts or embankment sections shall not be steeper than 2:1(H:V) without approval by competent soils engineer in a soils report filed with and approved by the City Engineer. ACO § 9-4.615
 6. Disposal of storm water drainage by means of ponding areas shall be permitted only with the approval of the City Engineer after a study of the proposed disposal basin topography and soil characteristics and only where no other reasonable method of disposal is feasible. ACO § 9-4.625
 7. Subdivisions shall be protected from inundation, flood sheet overflow, ponding of local storm waters, springs, and other surface waters. The design of improvements shall be such that water occurring within the subdivision will be carried off such subdivision without injury to any improvements, residential sites, or residences to be installed on sites within the subdivision or to adjoining areas. ACO § 9-4.622(A)(1)
 8. Waters occurring within the subdivision shall be carried to a storm drainage facility or to a natural watercourse by such improvements as may be required to meet City code design standards. The drainage design within the subdivision shall accommodate anticipated future development within the drainage area. Any off-tract outlet drainage facility required to carry storm water from the proposed subdivision to a defined channel or conduit shall be made adequate for the ultimate stage of development in the drainage area. ACO § 9-4.622(A)(2)
 9. Runoff quantities shall be determined by the modified rational method, using basic data supplied by the Flood Control District. Drainage facilities directly affecting the proposed subdivision shall have the following minimum capacities:
 - a. Major drainage channels and conduits -- 50-year storm
 - b. Secondary drainage channels and conduits -- 25-year storm
 - c. Minor drainage facilities --10-year storm. ACO § 9-4.622(B)(1)(2)
 10. Waters within street areas shall be placed in closed conduits where the maximum depth of computed flow exceeds the capacity of the gutter, creates a traffic hazard, or endangers property. ACO § 9-4.622(C)

11. The design of drainage channels, conduits, and appurtenances shall conform with the design standards of the Flood Control District. ACO § 9-4.622(D)
12. The proposed subdivision shall not cause or contribute to inundation or flood hazard conditions of existing inhabited areas, nor shall the improvement of the subdivision add sufficient runoff to cause damage to uninhabited areas. ACO § 9-4.622(E)
13. Culverts under driveway entrances for roadside ditches shall be adequate to carry the design flow but shall not be less than 12 inches inside diameter. ACO § 9-4.623(A)
14. The maximum gradient for earth ditches shall not exceed 4% nor be less than 1%. The minimum gradient for lined or paved ditches shall not be less than 0.5%. ACO § 9-4.623 (G)
15. Inlets shall be so designed that water shall be diverted into the catch basins without a reversal of direction of the flow of the water. ACO § 9-4.623(J)
16. Drainage structures shall account for tidal action and flood stage where applicable. Drainage shall be accomplished by gravity without surcharge in catch basins. TC shall be located 10' or higher above mean sea level as per USGS 1929 sea level datum. ACO § 9-4.623(K)
17. Max. design velocities for earth channels shall be 8 fps for major channels, 7 fps for secondary channels, and 6 fps for minor channels. Min. design velocities shall be 3 fps ACO § 9-4.624(A)(B)
18. Where the outlet velocity from a closed conduit or lined channel exceeds the maximum allowable velocity for earth channels, suitable protective works, such as riprap or an energy dissipator, shall be provided. ACO § 9-4.624(C)
19. If a soils investigation was previously performed for a site, the soils report must be referenced on the grading plan. If the soils report is more than two (2) years old a geotechnical report update letter from a qualified licensed professional must be referenced on the grading plan. The update letter addresses whether the recommendations of the previous soils report remain valid for the proposed project and if additional soil analysis is required. Requirements and recommendations of the soils report and update letter must be incorporated into the final design of the project.

C. Grading Plan Preparation

1. The Title Sheet shall contain the following information:
 - a. Project title, subdivision name & number
 - b. The preparing registered design professional's name, stamp, seal, and signature. All civil (including structural and geotechnical) engineering plans, calculations, specifications, and reports prepared by, or under the responsible charge of, a licensed civil engineer shall include his or her name and license number and bear the signature and seal or stamp of the licensee and the date of signing and sealing or stamping on the title, cover, or signature sheet, and on each plan sheet. BPC 6735
 - i. Add signature block: "This plan has been reviewed and conforms to the recommendations provided in the soils report dated _____. " Signature and date _____.
 - c. Signature block for Geotechnical Engineer confirming the project design complies with all project geotechnical reports and requirements.



DEVELOPMENT ENGINEERING DIVISION

- d. Property legal description (Tract, Lot, Block, and Grant Deed), Assessor’s Parcel Number (APN), and property / building address
- e. Vicinity Map, North arrow
- f. Vertical Datum (Benchmark) – NAVD 88 or NAVD29 with adjustment calculation to NAVD88
- g. Sheet index, listed by page and title
- h. Sheet index map
- i. Legend
- j. Abbreviations
- k. Table of Earthwork Quantities: Cut & Fill (CY)
 - i. If earthwork for the project is not balanced, or if any hauling is required, a proposed haul route detail shall be included.
- l. Required City Grading Plan Notes:
 - i. ALL OF THE GRADING PROCEDURES, RECOMMENDATIONS, AND SPECIFICATIONS THAT ARE INDICATED ON THE GEOTECHNICAL REPORT NO. _____, DATED _____, PREPARED BY _____ AND UPDATE REPORT/LETTER NO. _____, DATED _____, PREPARED BY _____ MUST BE ADHERED TO.
 - ii. THE USE OF CONSTRUCTION EQUIPMENT SHALL BE RESTRICTED TO WEEKDAYS BETWEEN THE HOURS OF 8:00 AM AND 5:00 PM OR AS APPROVED IN WRITING BY THE CITY ENGINEER.
 - iii. THE CONTRACTOR SHALL BE RESPONSIBLE FOR PREVENTING AIRBORNE DUST NUISANCE FROM THE CONSTRUCTION SITE BY WATERING AND/OR TREATING THE SITE IN SUCH A MANNER TO CONFINE DUST PARTICLES TO THE IMMEDIATE SURFACE OF WORK.
 - iv. THE CONTRACTOR SHALL BE RESPONSIBLE FOR ANY DAMAGE TO THE SITE OR SURROUNDING AREA DUE TO DUST OR EROSION RESULTING FROM THE WORK DONE BY THE CONTRACTOR.
 - v. THE CONTRACTOR IS RESPONSIBLE FOR ALL ASPECTS OF EROSION CONTROL AND SHALL INSTALL AND MAINTAIN PER ABAG/NPDES ANY DEVICES AND MEASURES NECESSARY TO THE SATISFACTION OF THE CITY ENGINEER AT ALL TIMES.
 - vi. THE GRADING OPERATION SHALL TAKE PLACE AT A TIME AND IN A MANNER AS TO NOT ALLOW EROSION AND SEDIMENTATION. THE SLOPES SHALL BE LANDSCAPED AND HYDROSEEDDED AS SOON AS POSSIBLE AFTER THE GRADING OPERATION CEASES. EROSION MEASURES SHALL BE IMPLEMENTED DURING ALL CONSTRUCTION PHASES IN ACCORDANCE WITH THE APPROVED EROSION CONTROL PLAN.
 - vii. PRIOR TO COMMENCEMENT OF ANY WORK ON ADJACENT PROPERTIES, THE DEVELOPER SHALL OBTAIN WRITTEN PERMISSION FROM THE AFFECTED PROPERTY OWNER AND SUBMIT A COPY OF THE PERMISSION TO THE CITY ENGINEER.



DEVELOPMENT ENGINEERING DIVISION

- viii. THE SOILS ENGINEER SHALL MONITOR THE MASS GRADING ON A FULL-TIME BASIS AND SHALL PERFORM FIELD DENSITY TESTING ON ALL FILL PLACED. THE SOILS ENGINEER SHALL BE NOTIFIED AT LEAST 48 HOURS PRIOR TO PLACEMENT OF FILL SO THAT ARRANGEMENTS CAN BE MADE FOR INSPECTION. UPON COMPLETION OF MASS GRADING THE SOILS ENGINEER SHALL PREPARE A REPORT ON THE MASS GRADING WHICH SHALL INCLUDE HIS OBSERVATIONS, FIELD DENSITY TEST RESULTS AND HIS PROFESSIONAL OPINION REGARDING COMPLIANCE OF THE MASS GRADING WITH RECOMMENDATIONS IN THE PROJECT SOIL REPORT.
- ix. THE PLANS SHALL INCLUDE A STATEMENT OF SPECIAL INSPECTIONS PREPARED BY THE REGISTERED DESIGN PROFESSIONAL IN RESPONSIBLE CHARGE. CBC 1705.6. THE STATEMENT MUST BE IN ACCORDANCE WITH CBC 1704.3. CBC TABLE 1705.6 REQUIRED SPECIAL INSPECTIONS AND TESTS OF SOILS SHALL BE PRINTED ON THE PLANS.
- x. PROVISIONS SHALL BE MADE TO CONTROL WATER RUNOFF AND EROSION DURING CONSTRUCTION OR DEMOLITION ACTIVITIES. THE PERSON MAKING OR CAUSING AN EXCAVATION TO BE MADE SHALL PROVIDE WRITTEN NOTICE TO THE OWNERS OF ADJOINING BUILDINGS ADVISING THEM THAT THE EXCAVATION IS TO BE MADE AND THAT THE ADJOINING BUILDINGS SHOULD BE PROTECTED. SAID NOTIFICATION SHALL BE DELIVERED NOT LESS THAN 10 DAYS PRIOR TO THE SCHEDULED DATE OF THE EXCAVATION. CBC 3307.1
- xi. IF THERE IS ANY EXPORT OR IMPORT OF EARTHWORK, THE LOCATION WHERE SOIL IS TAKEN TO OR FROM IS SUBJECT TO THE BUILDING DEPARTMENT APPROVAL. NO GRADING PERMIT WILL BE ISSUED UNTIL THE BUILDING DEPARTMENT APPROVES THE SOIL IMPORTATION/EXPORTATION LOCATION. CBC 105.3
- xii. EXCAVATIONS FOR ANY PURPOSE SHALL NOT REDUCE VERTICAL OR LATERAL SUPPORT FOR ANY FOUNDATION WITHOUT FIRST UNDERPINNING OR PROTECTING THE FOUNDATION AGAINST DETRIMENTAL LATERAL OR VERTICAL MOVEMENT, OR BOTH. CBC 1804.1
- xiii. EXCAVATION OUTSIDE THE FOUNDATION SHALL BE BACKFILLED WITH SOIL THAT IS FREE OF ORGANIC MATERIAL, CONSTRUCTION DEBRIS, COBBLES AND BOULDERS, OR A CONTROLLED LOW-STRENGTH MATERIAL (CLSM). CBC 1804.3 FOR CLSM REQUIREMENTS SEE DEFINITION IN CBC 1803.5.9
- xiv. NO ROCK OR SIMILAR IRREDUCIBLE MATERIAL GREATER THAN 12", OR AS INDICATED IN THE SOIL REPORT, (WHICHEVER IS SMALLER), IN ANY DIMENSION SHALL BE INCLUDED IN FILLS.
- xv. ALL FILL MATERIAL SHALL BE COMPACTED TO 90% OF MAXIMUM DENSITY AS DETERMINED BY ASTM D1557, MODIFIED PROCTOR, IN LIFTS NOT EXCEEDING 12" IN DEPTH, OR AS INDICATED IN THE SOIL REPORT, WHICHEVER IS MORE CONSERVATIVE.

DEVELOPMENT ENGINEERING DIVISION

- xvi. THE GROUND SURFACE SHALL BE PREPARED TO RECEIVE FILL BY REMOVING VEGETATION, TOPSOIL, AND OTHER UNSUITABLE MATERIALS, AND SCARIFYING THE GROUND TO PROVIDE A BOND WITH THE FILL MATERIAL.
 - xvii. PROVIDE BENCHING WHERE EXISTING GRADE IS AT A SLOPE STEEPER THAN 5(H):1(V) (20%) AND THE DEPTH OF THE FILL EXCEEDS 5'. A KEY SHALL BE PROVIDED THAT IS AT LEAST 10 FEET IN WIDTH AND 2 FEET IN DEPTH.
 - xviii. THE REQUIRED PERMANENT EROSION CONTROL DEVICES AND/OR METHODS SHALL BE INSTALLED AS SOON AS PRACTICABLE AND PRIOR TO CALLING FOR FINAL INSPECTIONS.
 - xix. THE TOP OF ANY EXTERIOR FOUNDATION SHALL EXTEND ABOVE THE ELEVATION OF STREET GUTTER AT POINT OF DISCHARGE OR THE INLET OF AN APPROVED DRAINAGE DEVICE A MINIMUM OF 12" PLUS 2% PER CBC 1808.7.4
 - xx. UPON COMPLETION OF PAD GRADING, THE CONTRACTOR SHALL REQUEST THAT THE ENGINEER CHECK THE GRADES. PADS SHALL NOT VARY MORE THAN 0.1 FOOT FROM THE ELEVATION SHOWN ON THE APPROVED GRADING PLAN. LOW POCKETS ON THE PADS WILL NOT BE ACCEPTED.
 - xxi. COMPACTION TESTS BY THE SOILS ENGINEER AND PAD ELEVATION CERTIFICATION BY THE CIVIL ENGINEER IS REQUIRED ON ALL LOTS.
 - xxii. CONTRACTOR SHALL CLEAN ALL ON-SITE STORM DRAIN FACILITIES IMMEDIATELY PRIOR TO AND AFTER A STORM EVENT. ADDITIONAL CLEANING MAY BE REQUIRED IF FOUND NECESSARY BY THE CITY INSPECTOR AND/OR CITY ENGINEER. CONTRACTOR SHALL INSPECT STORM DRAIN FACILITIES ONCE A MONTH DURING DRY SEASON AND CLEAN AS NECESSARY.
2. Detail Sheets shall contain all construction related details including, but not limited to:
- a. Typical street Section
 - b. Typical grading Section, also at Boundary and Phase lines
 - c. Modified field inlet Detail
 - d. Typical Lot Grading and Drainage Detail
 - e. Through-the-curb Drainage Detail
 - f. Modified Cul-de-sac Detail
 - g. Under-gutter Subdrain Detail
 - h. Retaining Wall Location Detail
 - i. Concrete-lined V-ditch Detail
 - j. Pad Detail
 - k. Straw wattle Detail
 - l. Slope & Pad Sections
 - m. Bio-retention Facility Detail
 - n. Bio-retention Facility Plan & Profile
 - o. Inlet and IMP Connection Detail
 - p. Erosion Control Plan and Notes

3. Plan Sheets shall contain the following information:
- a. All lot lines clearly identified, and lots #'s shown.
 - b. All existing contours, spot elevations, streets, streams, utilities, etc., shall be shown screened or as fine dashed lines and labeled.
 - c. Show existing and proposed grades and contours. Proposed grading conforms smoothly to existing contours.
 - d. Proposed contours and grading shall be shown as solid lines with proposed slopes labeled.
 - e. Existing topography shall be shown for at least 100' beyond the Boundary or grading limits/daylight line.
 - f. Grading shall not result in alternated watersheds, adverse impact or runoff onto adjacent properties or unmitigated overland release situations on site.
 - g. Transitional grading shall be shown and all measures necessary to provide interim grading and drainage and shall be detailed on plan.
 - h. All grading shall conform to CBC, City ordinance and any project conditions of approval and recommendations of the soils report. In the case of conflict, the more stringent standard/recommendation shall hold.
 - i. All streets and alleys identified by name (public and/or private).
 - j. Right-of-Way width and sidewalk shown.
 - k. Top-of-curb elevations shown at:
 - a. lot line extensions.
 - b. beginning curves.
 - c. ending curves.
 - d. catch basins.
 - e. at min. 50' intervals.
 - l. Provide pad elevations for each Lot.
 - m. Street and embankment slope percentages and direction of slope.
 - n. Grading limits, cut/fill line.
 - o. Retaining/sound walls including top-of-wall elevations and bottom-of-wall elevations.
 - p. Storm drain lines, appurtenant fixtures, rim elevations – all installed per hydrology and hydraulic calculations report.
 - q. Bio-retention facilities.
 - r. Temporary slopes and drainage facilities with any required temporary easements listed.
 - s. Trails and fencing
 - t. Designated recreation vehicle lots clearly defined.
 - u. Adequate proposed spot elevations or contours to verify pad slopes.
 - v. Lot grading provides for an overall 2% min. slope to the street or other approved drainage.
 - w. Proposed grading allows storm water to flow to drainage structures without interruption.

DEVELOPMENT ENGINEERING DIVISION

- x. Area at toe of fill graded to allow drainage to sheet flow away from fill, or a reinforced concrete-lined ditch (“V-ditch”) is provided.
- y. Terrace design shall be reviewed and approved by Geotechnical Engineer.
- z. Access is provided to all terraces and drainage facilities to permit cleaning and maintenance.
- aa. Min. slope for earth ditches/swales is 1% and max. slope is 4%
- bb. All public properties/right-of ways to be vacated or dedicated (if any), including the recorded map number.
- cc. Show any existing and/or new easements. Submit copies of all legally recorded easements.
- dd. Submit a separate sheet within the grading-plans showing the areas and depths (existing and proposed finished contour lines) of any contaminated or unstable soil condition reported in the soil report, and if they are to be removed and hauled away.
- ee. Indicate any ascending or descending slopes on the site plan.
- ff. Show existing grade and proposed finished grade in contour intervals and spot elevations to indicate general site slope and drainage pattern.
- gg. Plan shall show the existing grade on adjoining properties in sufficient detail to identify how grade changes will conform to the requirements of the code.
- hh. Indicate the location and size and identify the use and type of all the site’s existing structures and improvements to be demolished or to remain. If no demolitions are to be performed, then indicate so on the plans.
- ii. Demonstrate on the plans the methods of protection of adjoining property during excavation, fill, re-compaction, grading in accordance with CBC 3307.1.
- jj. Indicate the Top of Grate (TG) elevation of each proposed catch basin and area drain.
- kk. Provide cross sections of areas that are marked on the plans. Show in the cross sections the surface types and slopes; existing and proposed grades; curbs, gutters, and swales; retaining walls, underground structures, and pipes if any.
- ll. Identify the types of all the surface finishes (e.g., concrete pavement, concrete walkways, asphalt pavement, vegetated areas, landscaping, hardscaping, etc.)
- mm. Provide detailed drawings of construction of all called out curbs, swales, catch basins, gutters, and walkways.
- nn. The ground immediately adjacent to the foundation shall be sloped away from the building at a slope of not less than 20(H):1(V) (5%) for a minimum distance of 10’ measured perpendicular to the face of the wall. If physical obstructions or lot line prohibit 10’ of horizontal distance, a 5% slope shall be provided to an approved alternate method of diverting water way from the foundation. Swales used for this purpose shall be sloped a minimum of 2% where located within 10’ of the building foundation. Impervious surfaces within 10’ of the building foundation shall be sloped a minimum of 2% from the building. CBC 1804.4. All on-site subsurface drainage shall have a minimum slope of 1%.



DEVELOPMENT ENGINEERING DIVISION

- oo. Individual lot pads shall have a min. overall positive 2% drainage; they may be flat with 2% swales and 1% slope in subsurface drainage, or 1% sloping pad with 1% swale and 1% subsurface drainage. Elevations from high side of pad.
- pp. Slope banks shall be on the downside of lot.
- qq. Lots shall be graded to avoid cross runoff (lot to lot).
- rr. At side and rear lot lines, fences and property line shall be offset 1' from top of bank.
- ss. Overland release path and release elevations shall be noted on plans. Overland release is defined as the gutter flow elevation that runoff shall reach before it is released out of the subdivision. Runoff shall be released before the elevation at the low point (with plugged catch basins) exceeds 0.5' above top-of-curb elevation and lot flooding occurs.
- tt. On steep streets, place driveways on high side of pad. Max. centerline slope for driveways is 10% on grading plans and 12% on plot plans.
- uu. Fire access shall be provided for all open spaces and parks.

VI. LANDSCAPING AND IRRIGATION PLAN REQUIREMENTS

A. Design Requirements

1. Landscaping and irrigation design shall comply with:
 1. Parks and Rec / Planning Commission / City Council requirements.
 2. Conditions of approval
 3. Approved Tentative Map
 4. City of Antioch Municipal Code
 5. City of Antioch Construction Details

B. Landscape/Irrigation - Non-City Maintained

1. Non-City maintained landscaping plans shall contain:
 1. Irrigation system shall be an automated system that shall provide enough water to all landscaping.
 2. Irrigation shall comply with MWEL requirements.
 3. MWEL calculations are stamped and signed by a License Landscape Architect.
2. Show clear vision zones at all intersection returns and driveways. Tree trunks shall remain outside of clear vision zones. Canopies encroaching into clear vision zones shall be maintained at 8' and above. (AMC 9-5.1101).
3. Where trees are located within 15' of storm drainage system, Landscape Architect and Civil Engineer shall provide details demonstrating how the storm drainage system will be protected from tree roots. Details shall be approved by City Engineer.
4. Install backflow prevention at water meter connections. Backflow preventor shall comply with City standards.
5. Show street names.
6. Show streetlights – Proposed trees shall not conflict with streetlights.
7. Show masonry walls.
8. Provide setbacks from utilities per ST-19.
9. Show walls, fences, signs & utilities.

C. Landscape/Irrigation - City Maintained

1. Plans shall clearly delineate between public vs. private maintained landscaping areas per approved VTM.
2. Private and public landscaping shall be separate plan sets.
3. Show street names.
4. Show streetlights – Proposed trees shall not conflict with streetlights.
5. Show clear vision zones at all intersection returns and driveways. Tree trunks shall remain outside of clear vision zones. Canopies encroaching into clear vision zones shall be maintained at 8' and above. (AMC 9-5.1101).
6. Irrigation water service connections shall match locations shown on improvement plans.



DEVELOPMENT ENGINEERING DIVISION

7. Verify irrigation electrical pedestal connection matches location shown on joint trench plans.
8. Privately and publicly maintained landscaping requires separate irrigation controllers (water and electrical) and water meters.
9. Backflow preventor installed and shall comply with City standards.
10. Plants, shrubs and trees shall comply with City Approved Landscape Plant List dated 6-23-22.
11. All irrigation equipment shall match City details.
12. Where trees are located within 15' of storm drainage system, Landscape Architect and Civil Engineer shall provide detail demonstrating how the storm drainage system will be protected from tree roots. Details shall be approved by City Engineer.
13. Any requested landscaping/irrigation deviations shall be approved by City Engineer and Maintenance.
14. Show masonry walls.
15. Provide setbacks from utilities per ST-19.
16. Show walls, fences, signs & utilities.
17. Show or call out applicable City standard details on plans:
 1. L-03 Tree Staking and Irrigation
 - i. 2 Each, Rainbird 1800 Or Toro 570, 1GPM
 2. L-04 Pedestal Irrigation Controller
 - i. RainMaster Evolution DX3 SPED 16"x14"
 3. L-05 Sprinklers
 - i. Rainbird 1800 or Toro 570
 4. L-06 Quick Coupler
 - i. Rainbird 44LRC
 5. L-07 Quick Coupler (NPW)
 - i. Rainbird 44NP
 6. L-08 Light Energized Irrigation Controller
 - i. LEIT 4000
 7. L-09 Play Area Curb Section
 8. L-10 Slope Planting
 - i. 2 each, RainBird 1800 or Toro 570, 1 GPM
 9. L-11 Irrigation Master Control Valve
 - i. Rainbird EFB-CO Series
 10. L-12 Irrigation Remote Control Valve
 - i. Rainbird EFB-CP Series
 11. L-13 Isolation Gate Valve (2" OR <)
 12. L-14 Isolation Gate Valve (2.5" OR >)
 13. L-15 Irrigation Pipe Trench Section
 14. L-16 Thrust Blocks.

D. Medians

Medians shall comply with the following:

MEDIAN ISLANDS – 60% (hardscape): 40% (softscape) – Note, the below concrete and landscaping is for medians only.

1. CONCRETE (60%)

A. Maintained band and median paving finish pattern and color should be selected from one of the following stamped concretes:

i. Area: Somersville/Buchanan.

Manufacturer: Brickform www.brickform.com.

Pattern: Cheshire Cobble (Smooth Grout) Product ID:FM-525.

Color: San Diego Buff LC-2360.

ii. Area: SE Lone Tree Way.

Manufacturer: Brickform www.brickform.com.

Pattern: Herringbone Slate Product ID:FM-3550-S/O.

Color: Davis Silversmoke #8084" www.daviscolors.com.

Note: 0.25 lb/bag of Type I-II Cement set perpendicular to the curb; maintain pattern in irregular areas.

iii. Area: Heidorn Ranch Road (PW 569-H Median LP)

Manufacturer: Brickform www.brickform.com.

Pattern: Herringbone.

Color: Tile Red

iv. Area: Empire Avenue (PW 664_LP)

Manufacturer: Bomanite.

Pattern: Herringbone Slate. Set pattern perpendicular to 6" curb, maintain pattern in irregular areas.

Color: Davis Silversmoke. Mix 0.25LB #8084 per 94LB bag Type I-II Cement.

v. Area: Hillcrest Avenue (PW 487-A2_LP)

Manufacturer: Bomacron. Pattern: Ashlar Slate.

Color: Sonora Tan

vi. Area: Deer Valley Road (PW_____)

Manufacturer: Bomacron.

Pattern: Ashlar Slate.

Color: Sonora Tan

vii. Area: Sand Creek Road (PW 676-3, PW 697-6)

Manufacturer: Bomacron.

Pattern: Ashlar Slate.

Color: Brickform San Diego Buff LC-2360

DEVELOPMENT ENGINEERING DIVISION

- B. Maintenance band around medians should be a minimum 12" wide with a 6" wide curb (minimum 18" total width). Median noses and area 6' or less in width should be paved completely.
 - i. Maintenance band: Min. 4" thick, 12" wide, 3,000 psi concrete, over 4" min. Class II AB compacted 95%, over 95% compacted subgrade.
 - ii. Median paving: Min. 4" thick, 3,000 psi concrete, with 6x6x10 Gauge wire mesh, over 4" min. Class II AB compacted 95%, over 90% compacted subgrade.

2. LANDSCAPE (40%)

A. IRRIGATION

- i. Tap and corp stop, sized per irrigation valves
- ii. Water meter (W-04a)
- iii. Reduced pressure backflow preventer (W-11)
- iv. One (1) each 4" and 2" SCH 40 PVC conduits connecting landscape areas, 12" below depth of median pavement. Coordinate sleeve installation prior to flatwork installation.
- v. No drip or Netafim® Install spray heads or bubblers (L-05):
- vi. Rainbird/Toro 1812 Series, 57OZ pop-up spray head
- vii. Rainbird/Toro 1300AF or 570 Flood pressure compensating bubbler.
- viii. Install insulation gate valves in planting area (L-13, L-14)
- ix. Controller (L-04): RainMaster Evolution DX3 SPED 16"x14". 6 to 48 stations, with radio package to central system. Provide 120V power to controller.
- x. Less than 1 mile from Antenna, use Lo Gain
- xi. More than 1 mile from Antenna, use Hi Gain
- xii. City antennas are located at: Maintenance Yard, Walton Lane and Meadowcreek Park

B. PLANTS

- i. Groundcover
 - a. Trachelospermum asiaticum - Asian Jasmine Red Top
 - b. Myoporum parvifolium - Burgundy Carpet
- ii. Shrubs
 - a. Rapidless indica - Indian Hawthorn 'Ballerina'
 - b. Nandina domestica - Heavenly Bamboo 'Compacta', 'Gulfstream'
 - c. Tulbaghia violacea - Society Garlic 'Variegated Silverlace', 'Pink Agapanthus'
 - d. Pittosporum tenuifolium –
 - e. Rosa florinbunda – Floral carpet rose "White"
 - f. Rosemary officinalis – Prostrate Rosemary 'Prostratus'
 - g. Mulenbergia capillaris – Muhly grass 'Regal Mist'
 - h. Festuca mairei – Atlas Fescue

C. TREES

- i. Trees (park strips)
 - a. Lagerstroemia muskogee - Crape Myrtle
 - b. Lophostemon confertus - Tristanic conferta
 - c. Pistacia chinensis - Chinese Pistache 'Keith Davey' (only)
- ii. Trees (medians, cul-de-sacs)
 - a. Cercis Canadensis – Eastern Redbud
 - b. Lagerstroemia muskogee - Crape Myrtle
 - c. Lophostemon confertus - Tristanic conferta
 - d. Pistacia chinensis - Chinese Pistache 'Keith Davey' (only)
 - e. Quercus ilex – Holly Oak
 - f. Liquidambar styraciflua - Sweetgum 'Rotundiloba'
 - g. Ginkgo biloba - Saratoga Maidenhair 'Saratoga'
- iii. Trees (open space)
 - a. Quercus douglasii - Blue Oak
 - b. Quercus lobate -Valley Oak
 - c. Quercus agerifolia- Coast Live Oak
 - d. Quercus chrysolepis - Canyon Live Oak
 - e. Quercus wislizenii - Interior Live Oak
 - f. Aesculus californica - California Buckeye
 - g. Umbellularia californica - California Bay